

高速四通道数字隔离器

UMISO7740 WSOP16
UMISO7741 WSOP16
UMISO7742 WSOP16

1 描述

UMISO774x 系列均为高性能四通道单向数字隔离器，采用宽体封装设计，具有 5kV_{RMS} 隔离等级，支持 DC 至 150Mbps 超高速数据速率。该器件具备低功耗的特性，同时展现出优异的电磁抗扰性和低辐射特性，可有效隔离不同接地域，并阻隔高压/大电流瞬态干扰对敏感电路或人机接口电路的影响。各隔离通道由逻辑输入与输出缓冲器构成，并通过二氧化硅 (SiO_2) 电容隔离屏障实现电气隔离。每个输入端集成的施密特触发器在汽车应用中可提供卓越的抗噪性能。

UMISO774x 系列可提供完整的单向通道配置选项，以适配各类四通道系统设计。UMISO7740 系列四通道都为正向传输；UMISO7741 系列具有三路正向与一路反向通道，以适配隔离式 SPI、RS-485 通信等场景；UMISO7742 系列具有两路正向与两路反向通道，具备更高的设计灵活性；UMISO7741 与 UMISO7742 系列在隔离器两侧均配备独立的使能控制引脚，通过控制输出端为高阻态模式，可有效支持多主驱动架构以降低系统功耗。

UMISO774x 系列具备默认输出特性。输入电源未接通或处于开路状态时，后缀为 L 的型号默认输出低电平，后缀为 H 的型号默认输出高电平。具体型号后缀与选项的对应关系详见订购信息表。

UMISO774x 系列器件采用 WSOP16 宽体封装，工作环境温度范围为 $-40\text{ }^\circ\text{C}$ 至 $125\text{ }^\circ\text{C}$ 。

2 特性

- 数据速率: DC至150Mbps
- 稳健的数字信号电气隔离
 - 长使用寿命: >40 年
 - 高达 $5000\text{ V}_{\text{RMS}}$ 隔离电压
 - CMTI: $\pm 200\text{ kV}/\mu\text{s}$ (典型值)
- 宽电源电压范围: 2.375V至5.5V
- 工作环境温度范围: $-40\text{ }^\circ\text{C}$ to $125\text{ }^\circ\text{C}$
- 使能控制引脚，支持三态输出功能
- 采用WSOP16宽体封装
- 默认输出高电平 (UMISO774xH) 和默认输出低电平(UMISO774xL)选项
- 高电磁抗扰度
- 免初始化启动
- 低传播延迟和偏移
 - 传播延迟: $< 15\text{ ns}$
 - 脉冲宽度失真: $< 2.6\text{ ns}$
- 符合安全规范
 - DIN EN IEC 60747-17 (VDE 0884-17)
 - UL1577
 - IEC 61010-1 和 GB 4943.1-2022

3 Applications

- Industrial Automation
- Motor Control
- Medical Systems
- Isolated Power Supplies
- Solar Inverter
- Isolated ADC,DAC

4 Simplified Channel Structure

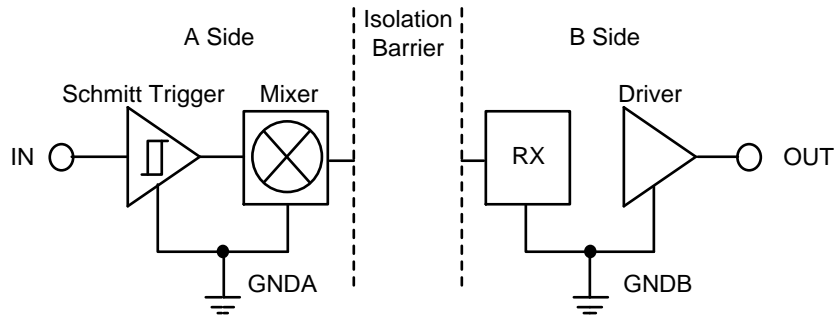

GNDA and GNDB are the isolated grounds for A side and B side respectively.

5 Selection Guide

Part Number	A Side Inputs	B Side Inputs	Default Output	Isolation Rating (V _{RMS})	Package
UMISO7740LWSG	4	0	Low	5000	WSOP16
UMISO7740HWSG	4	0	High	5000	WSOP16
UMISO7741LWSG	3	1	Low	5000	WSOP16
UMISO7741HWSG	3	1	High	5000	WSOP16
UMISO7742LWSG	2	2	Low	5000	WSOP16
UMISO7742HWSG	2	2	High	5000	WSOP16

6 Functional Block Diagrams

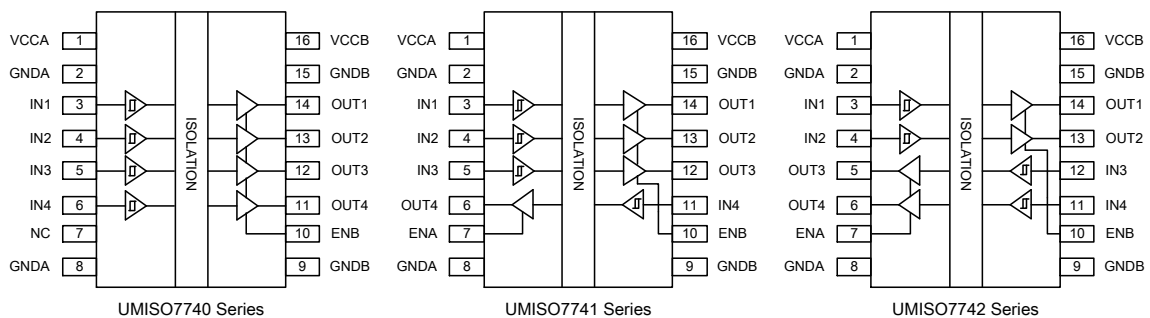

7 Ordering Information

Part Number	Mark Code	Package Type	Shipping Qty
UMISO7740LWSG	UMISO7740L	WSOP16	1500pcs/13Inch Tape & Reel
UMISO7740HWSG	UMISO7740H	WSOP16	1500pcs/13Inch Tape & Reel
UMISO7741LWSG	UMISO7741L	WSOP16	1500pcs/13Inch Tape & Reel
UMISO7741HWSG	UMISO7741H	WSOP16	1500pcs/13Inch Tape & Reel
UMISO7742LWSG	UMISO7742L	WSOP16	1500pcs/13Inch Tape & Reel
UMISO7742HWSG	UMISO7742H	WSOP16	1500pcs/13Inch Tape & Reel

8 Pin Configuration and Function

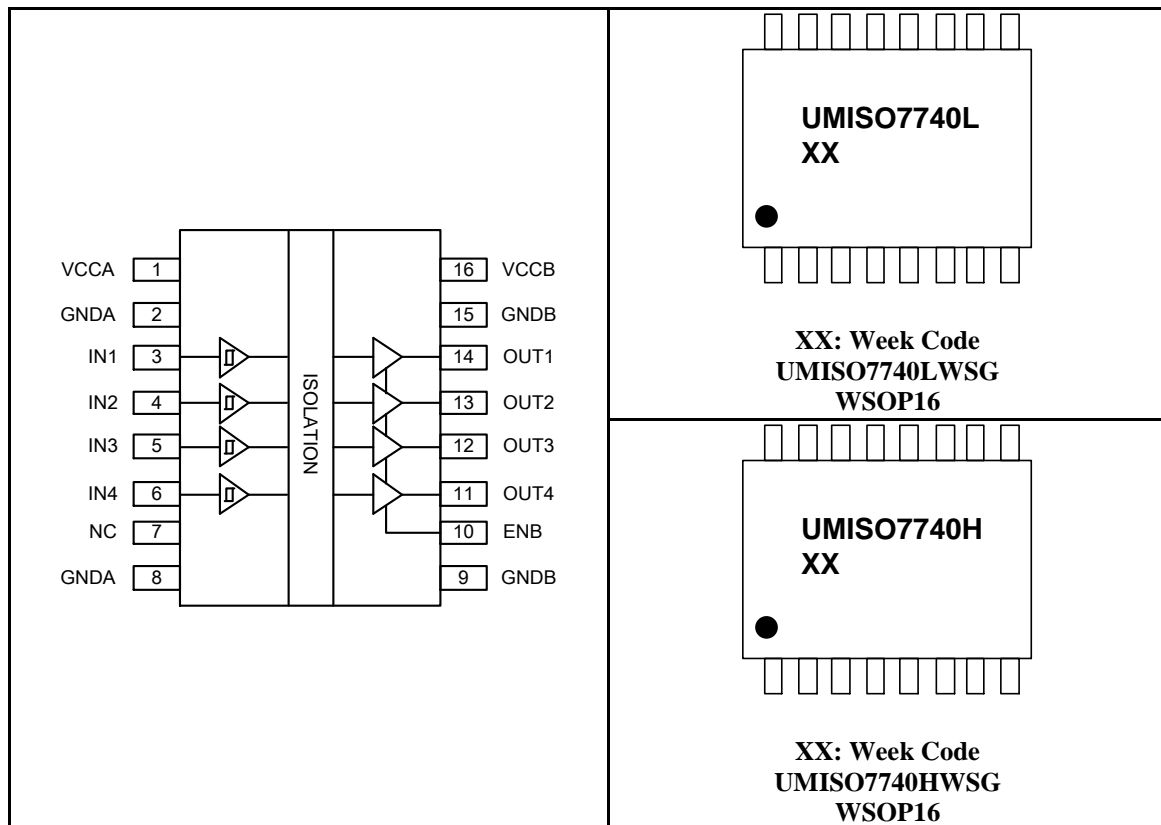

8 Pin Configuration and Function (continued)

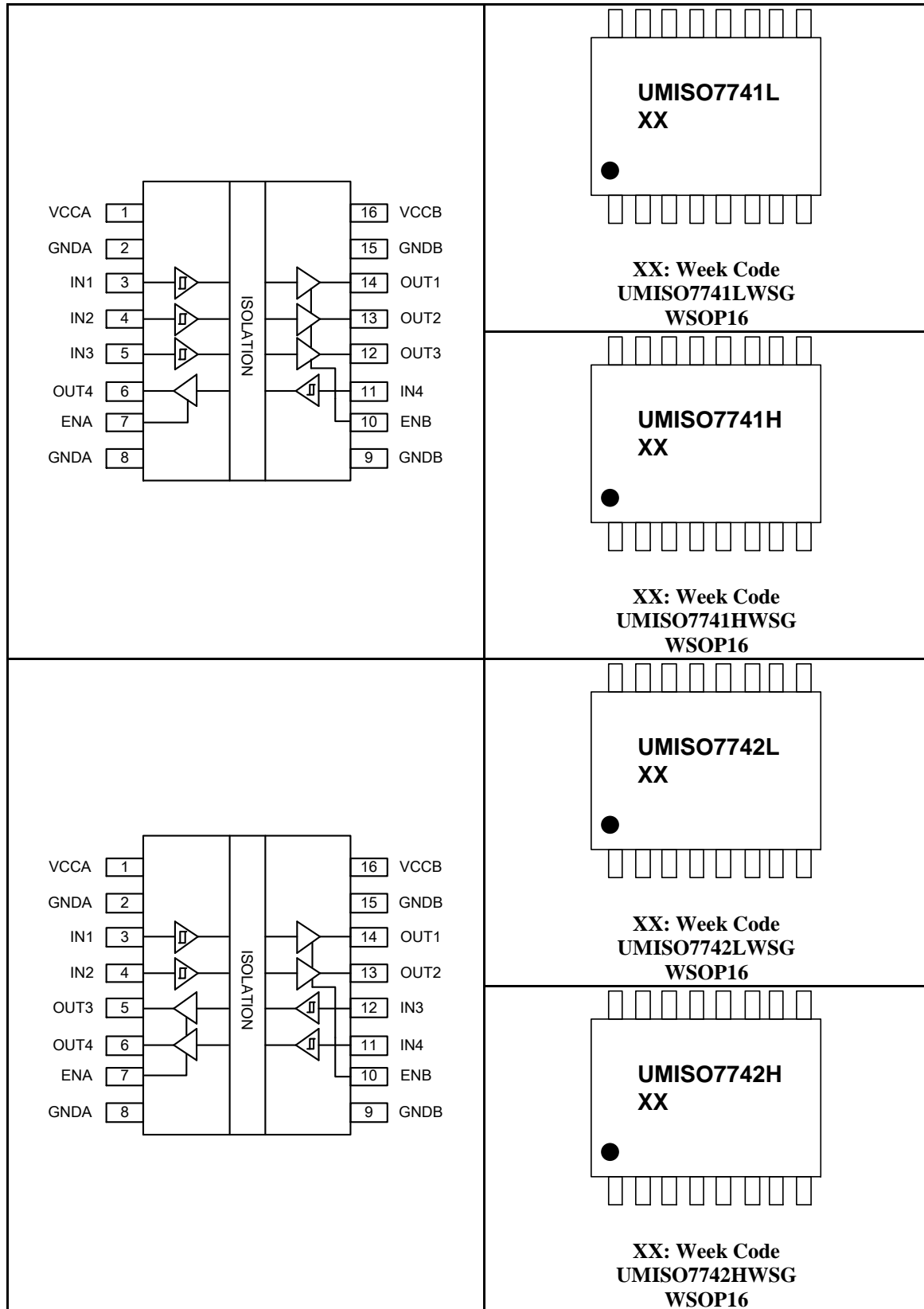

8 Pin Configuration and Function (continued)

Table 8-1. Pin Functions

Pin Name	Function
VCCA	Power supply for isolator side A.
GNDA	Ground reference for isolator side A.
IN1	Logic input 1, corresponds to logic output 1.
IN2	Logic input 2, corresponds to logic output 2.
IN3	Logic input 3, corresponds to logic output 3.
IN4	Logic input 4, corresponds to logic output4.
NC	Not connected.
ENA	Output enable A. Output pin on side A is enabled when ENA is high or floating; Output pin on side A is open and in high-impedance state when ENA is low.
GNDA	Ground reference for isolator side A.
GNDB	Ground reference for isolator side B.
ENB	Output enable B. Output pin on side B is enabled when ENB is high or floating; Output pin on side B is open and in high-impedance state when ENB is low.
OUT4	Logic output 4, OUT4 is the logic output for the IN4 input.
OUT3	Logic output 3, OUT3 is the logic output for the IN3 input.
OUT 2	Logic output 2, OUT2 is the logic output for the IN2 input.
OUT 1	Logic output 1, OUT1 is the logic output for the IN1 input.
GNDB	Ground reference for isolator side B.
VCCB	Power supply for isolator side B.

9 Specifications

9.1 Absolute Maximum Ratings (Note 1)

Symbol	Parameter	Conditions	Min	Typ	Max	Unit
V _{CCA}	Supply voltage for isolator side A	Note 2	-0.5		6	V
V _{CCB}	Supply voltage for isolator side B	Note 2	-0.5		6	V
V _I	Voltage on IN _x , OUT _x , EN _x	Note 3	-0.5		V _{CCX} +0.5	V
V _{ESD}	Human body model (HBM), per ANSI/ESDA/JEDEC JS-001	All pins		±8		kV
I _{LU}	Latch up, per JEDEC JESD78			200		mA
I _O	Output current		-15		15	mA
T _J	Junction temperature				150	°C
T _{STG}	Storage temperature		-65		150	°C

Note 1: Stresses beyond those listed under Absolute Maximum Ratings may cause permanent damage to the device. These are stress ratings only, which do not imply functional operation of the device at these or any other conditions beyond those indicated under Recommended Operating Conditions. Exposure to absolute-maximum-rated conditions for extended periods may affect device reliability.

Note 2: All voltage values are with respect to the local ground terminal (GNDA or GNDB) and are peak voltage values.

Note 3: Maximum voltage must not exceed 6 V.

9.2 Recommended Operating Conditions

Symbol	Parameter	Conditions	Min	Typ	Max	Unit
V _{CCA}	Supply voltage for isolator side A		2.375	3.3/5.0	5.5	V
V _{CCB}	Supply voltage for isolator side B		2.375	3.3/5.0	5.5	V
V _{CC(UVLO+)}	V _{CC} undervoltage-lockout threshold when supply voltage is rising		2	2.2	2.35	V
V _{CC(UVLO-)}	V _{CC} undervoltage-lockout threshold when supply voltage is falling		1.98	2.1	2.21	V
V _{HYS(UVLO)}	V _{CC} undervoltage-lockout threshold hysteresis		100	120	160	mV
I _{OH}	High-level output current	V _{CCO} = 5V (Note 1)	-4			mA
		V _{CCO} = 3.3V	-2			
		V _{CCO} = 2.5V	-1			
I _{OL}	Low-level output current	V _{CCO} = 5V			4	mA
		V _{CCO} = 3.3V			2	
		V _{CCO} = 2.5V			1	

9.2 Recommended Operating Conditions (continued)

Symbol	Parameter	Conditions	Min	Typ	Max	Unit
V _{IH}	INx Input High Voltage		2			V
V _{IL}	INx Input Low Voltage				0.8	V
V _{IH}	ENx Input High Voltage		0.7× V _{CCO}			V
V _{IL}	ENx Input Low Voltage				0.3× V _{CCO}	V
DR	Data rate				150	Mbps
T _A	Ambient temperature		-40	25	125	°C

Note 1: V_{CCO} = Output-side supply V_{CC}.

9.3 Thermal Information

Symbol	Parameter	Value	Unit	
R _{θJA}	Junction to ambient thermal	WSOP16	70.5	°C/W

9.4 Power Rating

Symbol	Parameter	Conditions	Min	Typ	Max	Unit
UMISO7740						
P _D	Maximum power dissipation	V _{CCA} = V _{CCB} = 5.5 V, C _L = 15 pF, T _J = 150°C, Input a 75 MHz, 50% duty cycle square wave.			315	mW
P _{DA}	Maximum power dissipation on A side				38	mW
P _{DB}	Maximum power dissipation on B side				277	mW
UMISO7741						
P _D	Maximum power dissipation	V _{CCA} = V _{CCB} = 5.5 V, C _L = 15 pF, T _J = 150°C, Input a 75 MHz, 50% duty cycle square wave.			318	mW
P _{DA}	Maximum power dissipation on A side				98	mW
P _{DB}	Maximum power dissipation on B side				220	mW
UMISO7742						
P _D	Maximum power dissipation	V _{CCA} = V _{CCB} = 5.5 V, C _L = 15 pF, T _J = 150°C, Input a 75 MHz, 50% duty cycle square wave.			312	mW
P _{DA}	Maximum power dissipation on A side				156	mW
P _{DB}	Maximum power dissipation on B side				156	mW

9.5 Insulation Specifications

Symbol	Parameter	Conditions	Value	Unit
			WSOP16	
CLR	External clearance	Shortest terminal-to-terminal distance through air	8	mm
CPG	External creepage	Shortest terminal-to-terminal distance across the package surface	8	mm
DTI	Distance through the insulation	Minimum internal gap (internal clearance)	16	μm
CTI	Comparative tracking index	DIN EN 60112 (VDE 0303-11); IEC 60112	>600	V
	Material group	Per IEC 60664-1	I	
	Overvoltage category per IEC 60664-1	Rated mains voltage $\leq 150 V_{RMS}$	I-IV	
		Rated mains voltage $\leq 300 V_{RMS}$	I-IV	
		Rated mains voltage $\leq 600 V_{RMS}$	I-IV	
		Rated mains voltage $\leq 1000 V_{RMS}$	I-II	
DIN EN IEC 60747-17 (VDE 0884-17) (Note 1)				
V_{IORM}	Maximum repetitive peak isolation voltage	AC voltage (bipolar)	1414	V_{PK}
V_{IOWM}	Maximum operating isolation voltage	AC voltage; time-dependent dielectric breakdown (TDDB) test	1000	V_{RMS}
		DC voltage	1414	V_{DC}
V_{IOTM}	Maximum transient isolation voltage	$V_{TEST} = V_{IOTM}$, $t = 60$ s (certified); $V_{TEST} = 1.2 \times V_{IOTM}$, $t = 1$ s (100% product test)	7070	V_{PK}
V_{IMP}	Maximum impulse voltage	Tested in air, 1.2/50 μs waveform per IEC 62368-1,	6000	V_{PK}
V_{IOSM}	Maximum surge isolation voltage	$V_{IOSM} \geq 1.3 \times V_{IMP}$; Tested in oil (qualification test), 1.2/50 μs waveform per IEC 62368-1	8000	V_{PK}

9.5 Insulation Specifications (continued)

Symbol	Parameter	Conditions	Value	Unit
			WSOP16	
q _{pd}	Apparent charge (Note 2)	Method a, after input/output safety test of the subgroup 2/3, $V_{ini} = V_{IOTM}$, $t_{ini} = 60$ s; $V_{pd(m)} = 1.2 \times V_{IORM}$, $t_m = 10$ s	≤5	pC
		Method a, after environmental test of the subgroup 1, $V_{ini} = V_{IOTM}$, $t_{ini} = 60$ s; $V_{pd(m)} = 1.3 \times V_{IORM}$, $t_m = 10$ s	≤5	pC
		Method b, at routine test (100% production test) and preconditioning (type test) $V_{ini} = 1.2 \times V_{IOTM}$, $t_{ini} = 1$ s; $V_{pd(m)} = 1.5 \times V_{IORM}$, $t_m = 1$ s (method b1) or $V_{pd(m)} = V_{ini}$, $t_m = t_{ini}$ (method b2)	≤5	pC
C _{IO}	Barrier capacitance, input to output (Note 3)	$V_{IO} = 0.4 \times \sin(2\pi ft)$, $f = 1$ MHz	~1.0	pF
R _{IO}	Isolation resistance (Note 3)	$V_{IO} = 500$ V, $T_A = 25$ °C	>10 ¹²	Ω
		$V_{IO} = 500$ V, 100 °C ≤ T_A ≤ 125 °C	>10 ¹¹	
		$V_{IO} = 500$ V at $T_s = 150$ °C	>10 ⁹	
	Pollution degree		2	
UL 1577				
V _{ISO}	Maximum withstanding isolation voltage	$V_{TEST} = V_{ISO}$, $t = 60$ s(qualification) $V_{TEST} = 1.2 \times V_{ISO}$, $t = 1$ s (100% production test)	5000	V _{RMS}

Note 1: This coupler is suitable for “safe electrical insulation” only within the safety ratings. Compliance with the safety ratings shall be ensured by means of suitable protective circuits.

Note 2: The characterization charge is discharging charge (pd) caused by partial discharge.

Note 3: Capacitance and resistance are measured with all pins on field-side and logic-side tied together.

9.6 Electrical Characteristics

9.6.1 Electrical Characteristics ($V_{CCA} = V_{CCB} = 5\text{ V} \pm 10\%$)

$T_A = -40$ to 125°C (over recommended operating conditions, unless otherwise specified).

Symbol	Parameter	Conditions	Min	Typ	Max	Unit
V_{OH}	Output high voltage	$I_{OH} = -4\text{ mA}$, see Figure 10-2 (Note 1)	$V_{CCO} - 0.4$	4.8		V
V_{OL}	Output low voltage	$I_{OL} = 4\text{ mA}$, see Figure 10-2		0.2	0.4	V
V_{IH}	INx input high		2.0			V
V_{IL}	INx input low				0.8	V
V_{IH}	ENx input high		$0.7V_{CCO}$			V
V_{IL}	ENx input low				$0.3V_{CCO}$	V
I_{IH}	High-level input leakage current	$V_{IH} = V_{CCA}$ at INx or ENx			20	μA
I_{IL}	Low-level input leakage current	$V_{IL} = 0\text{V}$ at INx	-20			μA
Z_O	Output impedance			50		Ω
CMTI Immunity	Common-mode transient	$V_I = V_{CCI}$ or 0 V , $V_{CM} = 1200\text{ V}$, see Figure 10-4 (Note 1)	150	200		$\text{kV}/\mu\text{s}$
C_I	Input capacitance (Note 2)	$V_I = V_{CC}/2 + 0.4 \times \sin(2\pi ft)$, $f = 1\text{ MHz}$, $V_{CC} = 5\text{ V}$		2		pF

9.6.2 Electrical Characteristics ($V_{CCA} = V_{CCB} = 3.3\text{ V} \pm 10\%$)

$T_A = -40$ to 125°C (over recommended operating conditions, unless otherwise specified).

Symbol	Parameter	Conditions	Min	Typ	Max	Unit
V_{OH}	Output high voltage	$I_{OH} = -2\text{ mA}$, see Figure 10-2 (Note 1)	$V_{CCO} - 0.4$	3.2		V
V_{OL}	Output low voltage	$I_{OL} = 2\text{ mA}$, see Figure 10-2		0.1	0.4	V
V_{IH}	INx input high		2.0			V
V_{IL}	INx input low				0.8	V
V_{IH}	ENx input high		$0.7V_{CCO}$			V
V_{IL}	ENx input low				$0.3V_{CCO}$	V
I_{IH}	High-level input leakage current	$V_{IH} = V_{CCA}$ at INx or ENx			20	μA
I_{IL}	Low-level input leakage current	$V_{IL} = 0\text{V}$ at INx	-20			μA
Z_O	Output impedance			50		Ω
CMTI Immunity	Common-mode transient	$V_I = V_{CCI}$ or 0 V , $V_{CM} = 1200\text{ V}$, see Figure 10-4 (Note 1)	150	200		$\text{kV}/\mu\text{s}$
C_I	Input capacitance (Note 2)	$V_I = V_{CC}/2 + 0.4 \times \sin(2\pi ft)$, $f = 1\text{ MHz}$, $V_{CC} = 3.3\text{ V}$		2		pF

9.6.3 Electrical Characteristics ($V_{CCA} = V_{CCB} = 2.5\text{ V} \pm 5\%$)
 $T_A = -40$ to 125°C (over recommended operating conditions, unless otherwise specified).

Symbol	Parameter	Conditions	Min	Typ	Max	Unit
V_{OH}	Output high voltage	$I_{OH} = -1\text{ mA}$, see Figure 10-2 (Note 1)	$V_{CCO} - 0.4$	2.45		V
V_{OL}	Output low voltage	$I_{OL} = 1\text{ mA}$, see Figure 10-2		0.05	0.4	V
V_{IH}	INx input high		2.0			V
V_{IL}	INx input low				0.8	V
V_{IH}	ENx input high		$0.7V_{CCO}$			V
V_{IL}	ENx input low				$0.3V_{CCO}$	V
I_{IH}	High-level input leakage current	$V_{IH} = V_{CCA}$ at INx or ENx			20	μA
I_{IL}	Low-level input leakage current	$V_{IL} = 0\text{V}$ at INx	-20			μA
Z_O	Output impedance			50		Ω
CMTI Immunity	Common-mode transient	$V_I = V_{CCI}$ or 0 V , $V_{CM} = 1200\text{ V}$, see Figure 10-4 (Note 1)	150	200		$\text{kV}/\mu\text{s}$
C_I	Input capacitance (Note 2)	$V_I = V_{CC}/2 + 0.4 \times \sin(2\pi ft)$, $f = 1\text{ MHz}$, $V_{CC} = 2.5\text{V}$		2		pF

 Note 1: V_{CCI} = Input-side supply V_{CC} , V_{CCO} = Output-side supply V_{CC} .

Note 2: Measured from pin to Ground.

9.7 Supply Current Characteristics
9.7.1 Supply Current Characteristics ($V_{CCA} = V_{CCB} = 5\text{ V} \pm 10\%$)
 $T_A = -40$ to 125°C (over recommended operating conditions, unless otherwise specified).

Symbol	Parameter	Conditions	Min	Typ	Max	Unit
UMISO7740						
I_{CCA}	Supply Current - Outputs disabled	$ENB = 0\text{ V}$; $V_{IN} = 0\text{V}$ (UMISO7740L); $V_{IN} = V_{CCA}$ (UMISO7740H)		1.4	2.0	mA
I_{CCB}				3.6	5.5	
I_{CCA}		$ENB = 0\text{ V}$; $V_{IN} = V_{CCA}$ (UMISO7740L); $V_{IN} = 0\text{V}$ (UMISO7740H)		10.5	13.8	
I_{CCB}				3.7	5.5	

9.7.1 Supply Current Characteristics ($V_{CCA} = V_{CCB} = 5\text{ V} \pm 10\%$)

$V_{CCA} = V_{CCB} = 5\text{ V} \pm 10\%$, $T_A = -40$ to 125°C (over recommended operating conditions, unless otherwise specified).

Symbol	Parameter	Conditions	Min	Typ	Max	Unit	
I_{CCA}	Supply Current - DC signal	$ENB = V_{CCB}$; $V_{IN} = 0\text{V}$ (UMISO7740L); $V_{IN} = V_{CCA}$ (UMISO7740H)		1.4	2.0	mA	
I_{CCB}				3.8	5.6		
I_{CCA}		$ENB = V_{CCB}$; $V_{IN} = V_{CCA}$ (UMISO7740L); $V_{IN} = 0\text{V}$ (UMISO7740H)		10.5	13.8		
I_{CCB}				3.9	5.5		
I_{CCA}	Supply Current - AC signal	$ENB = V_{CCB}$, all channels switching with 50% duty cycle square wave clock input with 5V amplitude; $C_L = 15\text{ pF}$ for each channel.	1Mbps		5.9		6.6
I_{CCB}					4.2		5.6
I_{CCA}			10Mbps		6.0		6.8
I_{CCB}					7.0		9.6
I_{CCA}			100Mbps		7.8	8.4	
I_{CCB}					33.8	40.1	
UMISO7741							
I_{CCA}	Supply Current - Outputs disabled	$ENA = ENB = 0\text{ V}$; $V_{IN} = 0\text{V}$ (UMISO7741L); $V_{IN} = V_{CCI}$ (UMISO7741H) (Note 1)		2.2	3.1	mA	
I_{CCB}					3.6		5.6
I_{CCA}		$ENA = ENB = 0\text{ V}$; $V_{IN} = V_{CCI}$ (UMISO7741L); $V_{IN} = 0\text{V}$ (UMISO7741H)		9.1	12.8		
I_{CCB}					6.0		9.7

9.7.1 Supply Current Characteristics ($V_{CCA} = V_{CCB} = 5\text{ V} \pm 10\%$)

$V_{CCA} = V_{CCB} = 5\text{ V} \pm 10\%$, $T_A = -40$ to 125°C (over recommended operating conditions, unless otherwise specified).

Symbol	Parameter	Conditions	Min	Typ	Max	Unit	
I_{CCA}	Supply Current - DC signal	$EN_A = EN_B = V_{CCI}$; $V_{IN} = 0\text{V}$ (UMISO7741L); $V_{IN} = V_{CCI}$ (UMISO7741H)		2.2	3.1	mA	
I_{CCB}				3.7	5.6		
I_{CCA}		$EN_A = EN_B = V_{CCI}$; $V_{IN} = V_{CCI}$ (UMISO7741L); $V_{IN} = 0\text{V}$ (UMISO7741H)		9.2	12.8		
I_{CCB}				6.1	9.7		
I_{CCA}	Supply Current - AC signal	$EN_A = EN_B = V_{CCI}$, all channels switching with 50% duty cycle square wave clock input with 5V amplitude; $C_L = 15\text{ pF}$ for each channel.	1Mbps		5.7		7.6
I_{CCB}					4.9		7.3
I_{CCA}			10Mbps		6.3		8.2
I_{CCB}					6.8		9.5
I_{CCA}			100Mbps		12.7	15.8	
I_{CCB}					25.2	32.1	
UMISO7742							
I_{CCA}	Supply Current - Outputs disabled	$EN_A = EN_B = 0\text{ V}$; $V_{IN} = 0\text{V}$ (UMISO7742L); $V_{IN} = V_{CCI}$ (UMISO7742H) (Note 1)		2.9	4.7	mA	
I_{CCB}				2.9	4.7		
I_{CCA}		$EN_A = EN_B = 0\text{ V}$; $V_{IN} = V_{CCI}$ (UMISO7742L); $V_{IN} = 0\text{V}$ (UMISO7742H)		7.5	11.6		
I_{CCB}				7.5	11.6		

9.7.1 Supply Current Characteristics ($V_{CCA} = V_{CCB} = 5\text{ V} \pm 10\%$)

$V_{CCA} = V_{CCB} = 5\text{ V} \pm 10\%$, $T_A = -40$ to 125°C (over recommended operating conditions, unless otherwise specified).

Symbol	Parameter	Conditions	Min	Typ	Max	Unit	
I_{CCA}	Supply Current - DC signal	$EN_A = EN_B = V_{CCI}$; $V_{IN} = 0\text{V}$ (UMISO7742L); $V_{IN} = V_{CCI}$ (UMISO7742H)		3.0	4.7	mA	
I_{CCB}				3.0	4.7		
I_{CCA}		$EN_A = EN_B = V_{CCI}$; $V_{IN} = V_{CCI}$ (UMISO7742L); $V_{IN} = 0\text{V}$ (UMISO7742H)		7.6	11.6		
I_{CCB}				7.6	11.6		
I_{CCA}	Supply Current - AC signal	$EN_A = EN_B = V_{CCI}$, all channels switching with 50% duty cycle square wave clock input with 5V amplitude; $C_L = 15\text{ pF}$ for each channel.	1Mbps		5.5		8.6
I_{CCB}					5.5		8.6
I_{CCA}			10Mbps		6.5		9.4
I_{CCB}					6.5		9.4
I_{CCA}			100Mbps		17.6	23.1	
I_{CCB}					16.6	23.1	

9.7.2 Supply Current Characteristics ($V_{CCA} = V_{CCB} = 3.3\text{ V} \pm 10\%$)

$V_{CCA} = V_{CCB} = 3.3\text{ V} \pm 10\%$, $T_A = -40$ to 125°C (over recommended operating conditions, unless otherwise specified).

Symbol	Parameter	Conditions	Min	Typ	Max	Unit
UMISO7740						
I_{CCA}	Supply Current - Outputs disabled	$EN_B = 0\text{ V}$; $V_{IN} = 0\text{ V}$ (UMISO7740L); $V_{IN} = V_{CCA}$ (UMISO7740H)		1.4	1.9	mA
I_{CCB}				3.6	5.2	
I_{CCA}		$EN_B = 0\text{ V}$; $V_{IN} = V_{CCA}$ (UMISO7740L); $V_{IN} = 0\text{V}$ (UMISO7740H)		10.5	13.8	
I_{CCB}				3.7	5.2	

9.7.2 Supply Current Characteristics ($V_{CCA} = V_{CCB} = 3.3\text{ V} \pm 10\%$)

$V_{CCA} = V_{CCB} = 3.3\text{ V} \pm 10\%$, $T_A = -40$ to 125°C (over recommended operating conditions, unless otherwise specified).

Symbol	Parameter	Conditions	Min	Typ	Max	Unit	
I_{CCA}	Supply Current - DC signal	$ENB = V_{CCB}$; $V_{IN} = 0\text{V}$ (UMISO7740L); $V_{IN} = V_{CCA}$ (UMISO7740H)		1.4	2.0	mA	
I_{CCB}				3.7	5.6		
I_{CCA}		$ENB = V_{CCB}$; $V_{IN} = V_{CCA}$ (UMISO7740L); $V_{IN} = 0\text{V}$ (UMISO7740H)		10.5	13.8		
I_{CCB}				3.8	5.5		
I_{CCA}	Supply Current - AC signal	$ENB = V_{CCB}$, all channels switching with 50% duty cycle square wave clock input with 3.3V amplitude; $C_L = 15\text{ pF}$ for each channel.	1Mbps		5.9		6.6
I_{CCB}					3.9		5.6
I_{CCA}			10Mbps		5.9		6.6
I_{CCB}					5.8		7.6
I_{CCA}			100Mbps		7.3	7.8	
I_{CCB}					23.4	29.1	
UMISO7741							
I_{CCA}	Supply Current - Outputs disabled	$ENA = ENB = 0\text{ V}$; $V_{IN} = 0\text{V}$ (UMISO7741L); $V_{IN} = V_{CCI}$ (UMISO7741H) (Note 1)		2.1	3.1	mA	
I_{CCB}				3.5	5.6		
I_{CCA}		$ENA = ENB = 0\text{ V}$; $V_{IN} = V_{CCI}$ (UMISO7741L); $V_{IN} = 0\text{ V}$ (UMISO7741H)		9.1	12.8		
I_{CCB}				5.9	9.7		

9.7.2 Supply Current Characteristics ($V_{CCA} = V_{CCB} = 3.3\text{ V} \pm 10\%$)

$V_{CCA} = V_{CCB} = 3.3\text{ V} \pm 10\%$, $T_A = -40$ to 125°C (over recommended operating conditions, unless otherwise specified).

Symbol	Parameter	Conditions	Min	Typ	Max	Unit	
I_{CCA}	Supply Current - DC signal	$EN_A = EN_B = V_{CCI}$; $V_{IN} = 0\text{ V}$ (UMISO7741L); $V_{IN} = V_{CCI}$ (UMISO7741H)		2.1	3.1	mA	
I_{CCB}				3.6	5.6		
I_{CCA}		$EN_A = EN_B = V_{CCI}$; $V_{IN} = V_{CCI}$ (UMISO7741L); $V_{IN} = 0\text{ V}$ (UMISO7741H)		9.1	12.8		
I_{CCB}				6.0	9.7		
I_{CCA}	Supply Current - AC signal	$EN_A = EN_B = V_{CCI}$, all channels switching with 50% duty cycle square wave clock input with 3.3V amplitude; $C_L = 15\text{ pF}$ for each channel.	1Mbps		5.6		7.4
I_{CCB}					4.7		7.1
I_{CCA}			10Mbps		6.0		8.8
I_{CCB}					5.9		8.6
I_{CCA}			100Mbps		10.3	13.2	
I_{CCB}					18.5	23.5	
UMISO7742							
I_{CCA}	Supply Current - Outputs disabled	$EN_A = EN_B = 0\text{ V}$; $V_{IN} = 0\text{ V}$ (UMISO7742L); $V_{IN} = V_{CCI}$ (UMISO7742H) (Note 1)		2.8	4.7	mA	
I_{CCB}				2.8	4.7		
I_{CCA}		$EN_A = EN_B = 0\text{ V}$; $V_{IN} = V_{CCI}$ (UMISO7742L); $V_{IN} = 0\text{ V}$ (UMISO7742H)		7.5	11.6		
I_{CCB}				7.5	11.6		

9.7.2 Supply Current Characteristics ($V_{CCA} = V_{CCB} = 3.3\text{ V} \pm 10\%$)

$V_{CCA} = V_{CCB} = 3.3\text{ V} \pm 10\%$, $T_A = -40$ to 125°C (over recommended operating conditions, unless otherwise specified).

Symbol	Parameter	Conditions	Min	Typ	Max	Unit	
I_{CCA}	Supply Current - DC signal	$EN_A = EN_B = V_{CCI}$; $V_{IN} = 0\text{V}$ (UMISO7742L); $V_{IN} = V_{CCI}$ (UMISO7742H)		2.9	4.7	mA	
I_{CCB}				2.9	4.7		
I_{CCA}		$EN_A = EN_B = V_{CCI}$; $V_{IN} = V_{CCI}$ (UMISO7742L); $V_{IN} = 0\text{V}$ (UMISO7742H)		7.6	11.6		
I_{CCB}				7.6	11.6		
I_{CCA}	Supply Current - AC signal	$EN_A = EN_B = V_{CCI}$, all channels switching with 50% duty cycle square wave clock input with 3.3V amplitude; $C_L = 15\text{ pF}$ for each channel.	1Mbps		5.4		8.6
I_{CCB}					5.4		8.6
I_{CCA}			10Mbps		6.0		9.4
I_{CCB}					6.0		9.4
I_{CCA}			100Mbps		13.3	18.0	
I_{CCB}					12.8	18.0	

9.7.3 Supply Current Characteristics ($V_{CCA} = V_{CCB} = 2.5\text{ V} \pm 5\%$)

$V_{CCA} = V_{CCB} = 2.5\text{ V} \pm 5\%$, $T_A = -40$ to 125°C (over recommended operating conditions, unless otherwise specified).

Symbol	Parameter	Conditions	Min	Typ	Max	Unit
UMISO7740						
I_{CCA}	Supply Current - Outputs disabled	$EN_B = 0\text{ V}$; $V_{IN} = 0\text{V}$ (UMISO7740L); $V_{IN} = V_{CCA}$ (UMISO7740H)		1.4	1.9	mA
I_{CCB}				3.6	5.2	
I_{CCA}		$EN_B = 0\text{ V}$; $V_{IN} = V_{CCA}$ (UMISO7740L); $V_{IN} = 0\text{V}$ (UMISO7740H)		10.5	13.8	
I_{CCB}				3.7	5.2	

9.7.3 Supply Current Characteristics ($V_{CCA} = V_{CCB} = 2.5\text{ V} \pm 5\%$)

$V_{CCA} = V_{CCB} = 2.5\text{ V} \pm 5\%$, $T_A = -40$ to 125°C (over recommended operating conditions, unless otherwise specified).

Symbol	Parameter	Conditions	Min	Typ	Max	Unit	
I_{CCA}	Supply Current - DC signal	$ENB = V_{CCB}$; $V_{IN} = 0\text{V}$ (UMISO7740L); $V_{IN} = V_{CCA}$ (UMISO7740H)		1.4	2.0	mA	
I_{CCB}				3.7	5.6		
I_{CCA}		$ENB = V_{CCB}$; $V_{IN} = V_{CCA}$ (UMISO7740L); $V_{IN} = 0\text{V}$ (UMISO7740H)		10.5	13.8		
I_{CCB}				3.8	5.5		
I_{CCA}	Supply Current - AC signal	$ENB = V_{CCB}$, all channels switching with 50% duty cycle square wave clock input with 2.5V amplitude; $C_L = 15\text{ pF}$ for each channel.	1Mbps		5.9		6.6
I_{CCB}					3.9		5.6
I_{CCA}			10Mbps		5.9		6.6
I_{CCB}					5.3		7.0
I_{CCA}			100Mbps		7.1	7.8	
I_{CCB}					18.6	22.5	
UMISO7741							
I_{CCA}	Supply Current - Outputs disabled	$ENA = ENB = 0\text{ V}$; $V_{IN} = 0\text{V}$ (UMISO7741L); $V_{IN} = V_{CCI}$ (UMISO7741H) (Note 1)		2.3	3.1	mA	
I_{CCB}				3.5	5.6		
I_{CCA}		$ENA = ENB = 0\text{ V}$; $V_{IN} = V_{CCI}$ (UMISO7741L); $V_{IN} = 0\text{V}$ (UMISO7741H)		9.1	12.8		
I_{CCB}				5.9	9.7		

9.7.3 Supply Current Characteristics ($V_{CCA} = V_{CCB} = 2.5\text{ V} \pm 5\%$)

$V_{CCA} = V_{CCB} = 2.5\text{ V} \pm 5\%$, $T_A = -40$ to 125°C (over recommended operating conditions, unless otherwise specified).

Symbol	Parameter	Conditions	Min	Typ	Max	Unit	
I_{CCA}	Supply Current - DC signal	$EN_A = EN_B = V_{CCI}$; $V_{IN} = 0\text{V}$ (UMISO7741L); $V_{IN} = V_{CCI}$ (UMISO7741H)		2.1	3.1	mA	
I_{CCB}				3.6	5.6		
I_{CCA}		$EN_A = EN_B = V_{CCI}$; $V_{IN} = V_{CCI}$ (UMISO7741L); $V_{IN} = 0\text{V}$ (UMISO7741H)		9.2	12.8		
I_{CCB}				6.1	9.7		
I_{CCA}	Supply Current - AC signal	$EN_A = EN_B = V_{CCI}$, all channels switching with 50% duty cycle square wave clock input with 2.5V amplitude; $C_L = 15\text{ pF}$ for each channel.	1Mbps		5.6		7.6
I_{CCB}					4.6		7.1
I_{CCA}			10Mbps		5.8		8.8
I_{CCB}					5.5		8.2
I_{CCA}			100Mbps		9.1	12.2	
I_{CCB}					14.8	19.5	
UMISO7742							
I_{CCA}	Supply Current - Outputs disabled	$EN_A = EN_B = 0\text{ V}$; $V_{IN} = 0\text{V}$ (UMISO7742L); $V_{IN} = V_{CCI}$ (UMISO7742H) (Note 1)		2.8	4.7	mA	
I_{CCB}				2.8	4.7		
I_{CCA}		$EN_A = EN_B = 0\text{ V}$; $V_{IN} = V_{CCI}$ (UMISO7742L); $V_{IN} = 0\text{V}$ (UMISO7742H)		7.5	11.6		
I_{CCB}				7.5	11.6		

9.7.3 Supply Current Characteristics ($V_{CCA} = V_{CCB} = 2.5\text{ V} \pm 5\%$)

$V_{CCA} = V_{CCB} = 2.5\text{ V} \pm 5\%$, $T_A = -40$ to 125°C (over recommended operating conditions, unless otherwise specified).

Symbol	Parameter	Conditions	Min	Typ	Max	Unit	
I_{CCA}	Supply Current - DC signal	$EN_A = EN_B = V_{CCI}$; $V_{IN} = 0\text{V}$ (UMISO7742L); $V_{IN} = V_{CCI}$ (UMISO7742H)		2.8	4.7	mA	
I_{CCB}				2.8	4.7		
I_{CCA}		$EN_A = EN_B = V_{CCI}$; $V_{IN} = V_{CCI}$ (UMISO7742L); $V_{IN} = 0\text{V}$ (UMISO7742H)		7.5	11.6		
I_{CCB}				7.5	11.6		
I_{CCA}	Supply Current - AC signal	$EN_A = EN_B = V_{CCI}$, all channels switching with 50% duty cycle square wave clock input with 2.5V amplitude; $C_L = 15\text{ pF}$ for each channel.	1Mbps		5.3		8.6
I_{CCB}					5.3		8.6
I_{CCA}			10Mbps		5.7		9.4
I_{CCB}					5.7		9.4
I_{CCA}			100Mbps		11.0		16.6
I_{CCB}					11.0		16.6

Note 1: $V_{CCI} =$ Input-side supply V_{CC} .

9.8 Electrical Characteristics (Dynamic)

9.8.1 Electrical Characteristics (Dynamic) ($V_{CCA} = V_{CCB} = 5\text{ V} \pm 10\%$)

$V_{CCA} = V_{CCB} = 5\text{ V} \pm 10\%$, $T_A = -40$ to 125°C (over recommended operating conditions, unless otherwise specified).

Symbol	Parameter	Conditions	Min	Typ	Max	Unit
DR	Data rate				150	Mbps
PWM _{MIN}	Minimum pulse width				5	ns
t _{PLH}	Propagation delay time	see Figure 10-1	4.5	10	16	ns
t _{PHL}		see Figure 10-1	4.5	10	16	ns
PWD	Pulse width distortion, $ t_{PLH} - t_{PHL} $	see Figure 10-1			2.6	ns
t _{SK(O)}	Channel-to-Channel output skew time (Note 1)	Same-direction channels			2.6	ns
t _{SK(PP)}	Part-to-Part output skew time (Note 2)			2.2	5	ns
t _R	Output signal rise time	see Figure 10-1		2	3	ns
t _F	Output signal fall time	see Figure 10-1		1	3	ns
t _{PHZ}	Disable propagation delay, high output to high impedance	see Figure 10-2	10.9	12.8	16.1	ns
t _{PLZ}	Disable propagation delay, low output to high impedance	see Figure 10-2	11.6	13.9	16.6	ns
t _{PZH}	Enable propagation delay, high impedance to high output	UMISO774xL	see Figure 10-2	7.7	12	ns
		UMISO774xH		7.7	12	
t _{PZL}	Enable propagation delay, high impedance to low output	UMISO774xL	see Figure 10-2	7.7	12	ns
		UMISO774xH		7.7	12	
t _{DO}	Default output delay time from input power loss	see Figure 10-3		60	70	μs
t _{SU}	Start-up time			12	20	μs

9.8.2 Electrical Characteristics (Dynamic) ($V_{CCA} = V_{CCB} = 3.3 \text{ V} \pm 10\%$)

$V_{CCA} = V_{CCB} = 3.3 \text{ V} \pm 10\%$, $T_A = -40$ to 125°C (over recommended operating conditions, unless otherwise specified).

Symbol	Parameter	Conditions	Min	Typ	Max	Unit
DR	Data rate				150	Mbps
PWM _{MIN}	Minimum pulse width				5	ns
t _{PLH}	Propagation delay time	see Figure 10-1	4.5	10.6	16	ns
t _{PHL}		see Figure 10-1	4.5	10.6	16	ns
PWD	Pulse width distortion, $ t_{PLH} - t_{PHL} $	see Figure 10-1			2.6	ns
t _{SK(O)}	Channel-to-Channel output skew time (Note 1)	Same-direction channels			2.6	ns
t _{SK(PP)}	Part-to-Part output skew time (Note 2)			2.2	5	ns
t _R	Output signal rise time	see Figure 10-1		2.4	3.5	ns
t _F	Output signal fall time	see Figure 10-1		2.3	3.5	ns
t _{PHZ}	Disable propagation delay, high output to high impedance	see Figure 10-2		14.2	18.8	ns
t _{PLZ}	Disable propagation delay, low output to high impedance	see Figure 10-2		18.2	21.6	ns
t _{PZH}	Enable propagation delay, high impedance to high output	UMISO774xL	see Figure 10-2	8.6	14	ns
		UMISO774xH		8.6	14	
t _{PZL}	Enable propagation delay, high impedance to low output	UMISO774xL	see Figure 10-2	8.6	14	ns
		UMISO774xH		8.6	14	
t _{DO}	Default output delay time from input power loss	see Figure 10-3		60	70	μs
t _{SU}	Start-up time			12	20	μs

9.8.3 Electrical Characteristics (Dynamic) ($V_{CCA} = V_{CCB} = 2.5\text{ V} \pm 5\%$)

$V_{CCA} = V_{CCB} = 2.5\text{ V} \pm 5\%$, $T_A = -40$ to 125°C (over recommended operating conditions, unless otherwise specified).

Symbol	Parameter	Conditions	Min	Typ	Max	Unit	
DR	Data rate				150	Mbps	
PWM _{MIN}	Minimum pulse width				5	ns	
t _{PLH}	Propagation delay time	see Figure 10-1	5	11.8	18	ns	
t _{PHL}		see Figure 10-1	5	11	18	ns	
PWD	Pulse width distortion, $ t_{PLH} - t_{PHL} $	see Figure 0-1			2.6	ns	
t _{SK(O)}	Channel-to-Channel output skew time (Note 1)	Same-direction channels			2.6	ns	
t _{SK(PP)}	Part-to-Part output skew time (Note 2)			2.2	5	ns	
t _R	Output signal rise time	see Figure 10-1		2.7	4	ns	
t _F	Output signal fall time	see Figure 10-1		2.6	4	ns	
t _{PHZ}	Disable propagation delay, high output to high impedance	see Figure 10-2		17.2	25.1	ns	
t _{PLZ}	Disable propagation delay, low output to high impedance	see Figure 10-2		23.1	27.5	ns	
t _{PZH}	Enable propagation delay, high impedance to high output	UMISO774xL	see Figure 10-2		10.5	17	ns
		UMISO774xH			10.5	17	
t _{PZL}	Enable propagation delay, high impedance to low output	UMISO774xL	see Figure 10-2		10.5	17	ns
		UMISO774xH			10.5	17	
t _{DO}	Default output delay time from input power loss	see Figure 10-3		60	70	μs	
t _{SU}	Start-up time			12	20	μs	

Note 1: t_{SK(O)} is the skew between outputs of a single device with all driving inputs connected together and the outputs switching in the same direction while driving identical loads.

Note 2: t_{SK(PP)} is the magnitude of the difference in propagation delay times between any terminals of different devices switching in the same direction while operating at identical supply voltages, temperature, input signals and loads.

10 Parameter Measurement Information

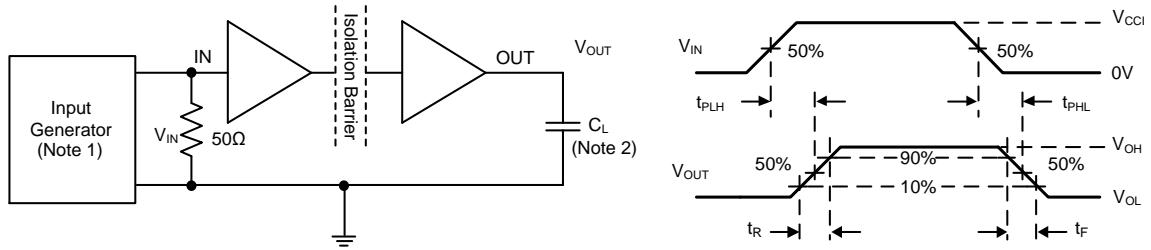

Note 1: A square wave generator provides V_{IN} input signal with characteristics: frequency $\leq 100\text{kHz}$, 50% duty cycle, $t_R \leq 3\text{ns}$, $t_F \leq 3\text{ns}$, $Z_{OUT} = 50\Omega$. At the input, 50Ω resistor is required to terminate input generator signal. It is not needed in actual application.

Note 2: $C_L = 15\text{pF}$ and includes external circuit (instrumentation and fixture etc.) capacitance. Since the load capacitance influence the output rising time, it's a key factor in the timing characteristic measurement.

Figure 10-1. Switching Characteristics Test Circuit and Voltage Waveforms

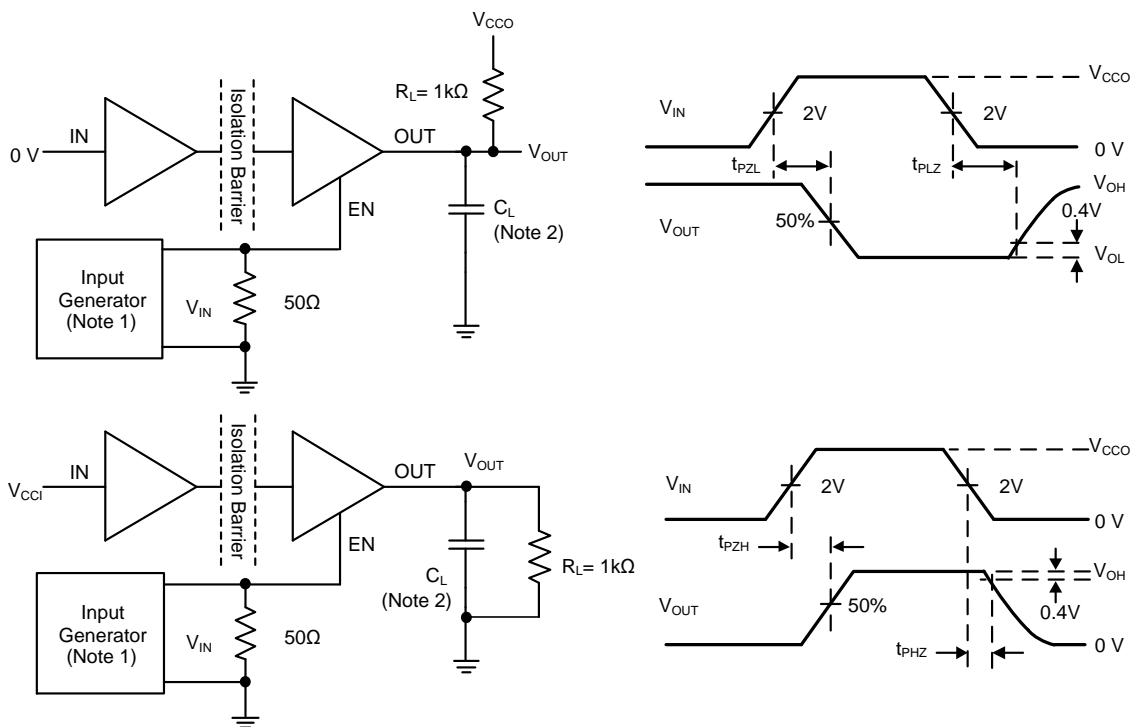

Note 1: A square wave generator provides V_{IN} input signal with characteristics: frequency $\leq 10\text{kHz}$, 50% duty cycle, $t_R \leq 3\text{ns}$, $t_F \leq 3\text{ns}$, $Z_{OUT} = 50\Omega$. At the input, 50Ω resistor is required to terminate input generator signal. It is not needed in actual application.

Note 2: $C_L = 15\text{pF}$ and includes external circuit (instrumentation and fixture etc.) capacitance. Since the load capacitance influence the output rising time, it's a key factor in the timing characteristic measurement.

Figure 10-2. Enable/Disable Propagation Delay Time Test Circuit and Waveform

10 Parameter Measurement Information (continued)

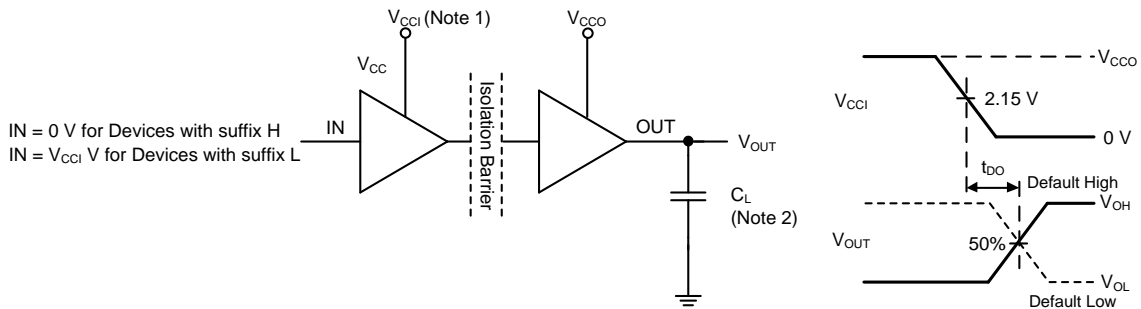

Note 1: Power Supply Ramp Rate = 10 mV/ns. V_{CCI} should ramp over 2.375V, and less than 5.5V.
Note 2: $C_L = 15\text{pF}$ and includes external circuit (instrumentation and fixture etc.) capacitance. Since the load capacitance influence the output rising time, it's a key factor in the timing characteristic measurement.

Figure 10-3. Default Output Delay Time Test Circuit and Voltage Waveforms

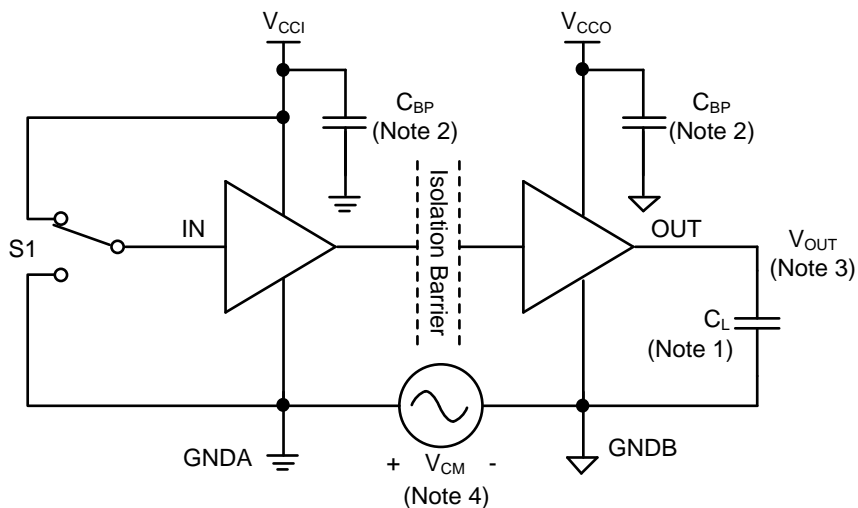

Note 1: $C_L = 15\text{pF}$ and includes external circuit (instrumentation and fixture etc.) capacitance.
Note 2: C_{BP} (0.1 ~ 1 μF) is bypass capacitance.
Note 3: Pass-fail criteria: the output must remain stable.
Note 4: The High Voltage Surge Generator generates repetitive high voltage surges with >1kV amplitude, rise time <10ns and fall time <10ns, to reach common-mode transient noise with >150kV/ μs slew rate.

Figure 10-4. Common-Mode Transient Immunity Test Circuit

11 Detailed Description

11.1 Overview

The UMISO774x devices are a family of automotive, four-channel digital galvanic isolators using Union’s full differential capacitive isolation technology. These devices have an ON-OFF keying (OOK) modulation scheme to transfer digital signals across the SiO₂ based isolation barrier between circuits with different power domains. The transmitter sends a high frequency carrier across the barrier to represent one digital state and sends no signal to represent the other digital state. The receiver demodulates the signal and recovers input signal at output through a buffer stage. With this OOK architecture, the UMISO774x devices build a robust data transmission path between different power domains, without any special start-up initialization requirement.

These devices also incorporate advanced full differential techniques to maximize the CMTI performance and minimize the radiated emissions due the high frequency carrier and I/O buffer switching.

11.2 Functional Block Diagram

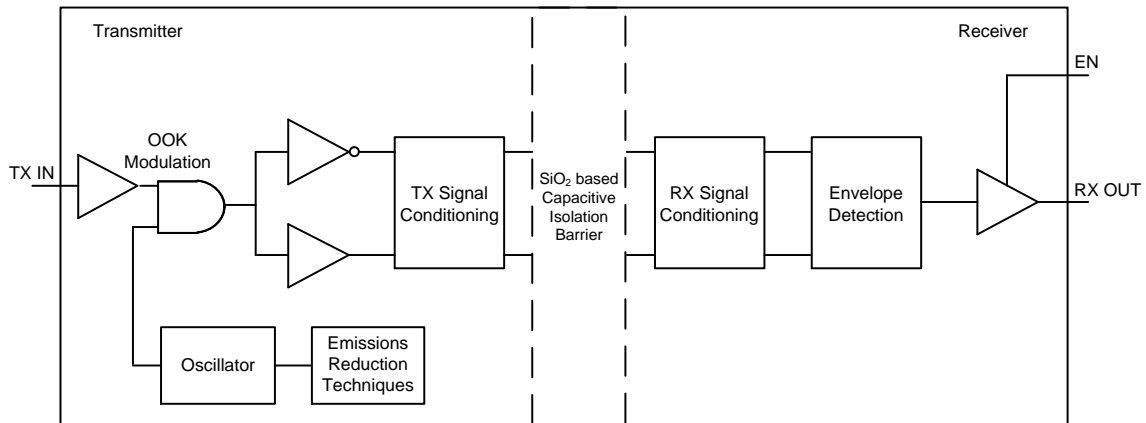

Figure 11-1. Functional Block Diagram of a Single Channel

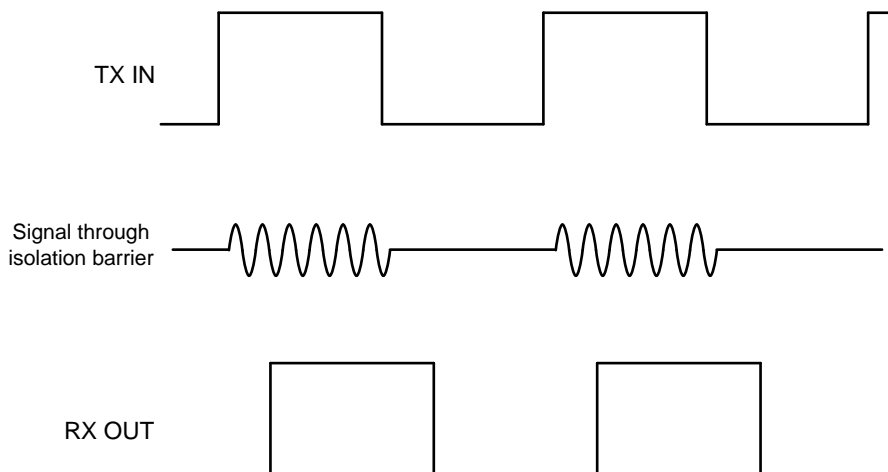

Figure 11-2. Conceptual Operation Waveforms of a Single Channel

11.3 Device Operation Modes (Note 1, 2, 3)

Table 11-1 lists the operation modes for the UMISO774x devices.

Table 11-1. Operation Mode Table (Note 1, 2, 3)

V _{CCI}	V _{CCO}	Enable (EN _x)	Input (IN _x)	Output (OUT _x)	Operation
X	PD	X	X	Undetermined	If the output side V _{CCO} is unpowered, a channel output is undetermined. (Note 4)
X	PU	L	X	Z	High impedance mode: A low level of Enable pin causes the output to be high impedance.
PD	PU	H or Open	X	Default	Default output mode: When V _{CCI} is unpowered, a channel output assumes the logic state based on its default option. Default is High for UMISO774xH and Low for UMISO774xL.
PU	PU	H or Open	H	H	Normal operation mode: A channel output follows the logic state of its input.
		H or Open	L	L	
		H or Open	Open	Default	Default output mode: When input is open, the corresponding channel output goes to its default logic state. Default is High for UMISO774xH and Low for UMISO774xL.

Note 1: V_{CCI} = Input-side V_{CC}; V_{CCO} = Output-side V_{CC}; PU = Powered up (V_{CC} ≥ V_{CC(UVLO+)}); PD = Powered down (V_{CC} ≤ V_{CC(UVLO-)}); X = Irrelevant; H = High level; L = Low level; Z = High Impedance.

Note 2: A strongly driven input signal can weakly power the floating V_{CC} through an internal protection diode and cause undetermined output.

Note 3: It is recommended to connect the enable inputs to external logic high or low level when the UMISO774x devices operate in noisy environments.

Note 4: The outputs are in undetermined state when V_{CC(UVLO+)} < V_{CCI}, V_{CCO} < V_{CC(UVLO-)}.

12 Application and Implementation

12.1 Application Information

The UMISO774x isolation ICs provide complete galvanic isolation between two power domains, protecting circuits from high common-mode transients and faults, and eliminating ground loops. In many applications, digital isolators are replacing optocouplers because they can reduce the power requirements and take up less board space while offering the same isolation capability. The UMISO774x devices are the high-performance, four-channel digital isolators. These devices come with enable pins on each side which can be used to put the respective outputs in high impedance for multi-master driving applications. Unlike optocouplers, which require external components to improve performance, provide bias, or limit current, the UMISO774x devices only require two external bypass capacitors to operate. To reduce ripple and the chance of introducing data errors, bypass V_{CCA} and V_{CCB} pins with $0.1\mu\text{F}$ to $1\mu\text{F}$ low-ESR ceramic capacitors to GNDA and GNDB respectively. Place the bypass capacitors as close to the power supply input pins as possible.

12.2 Typical Application

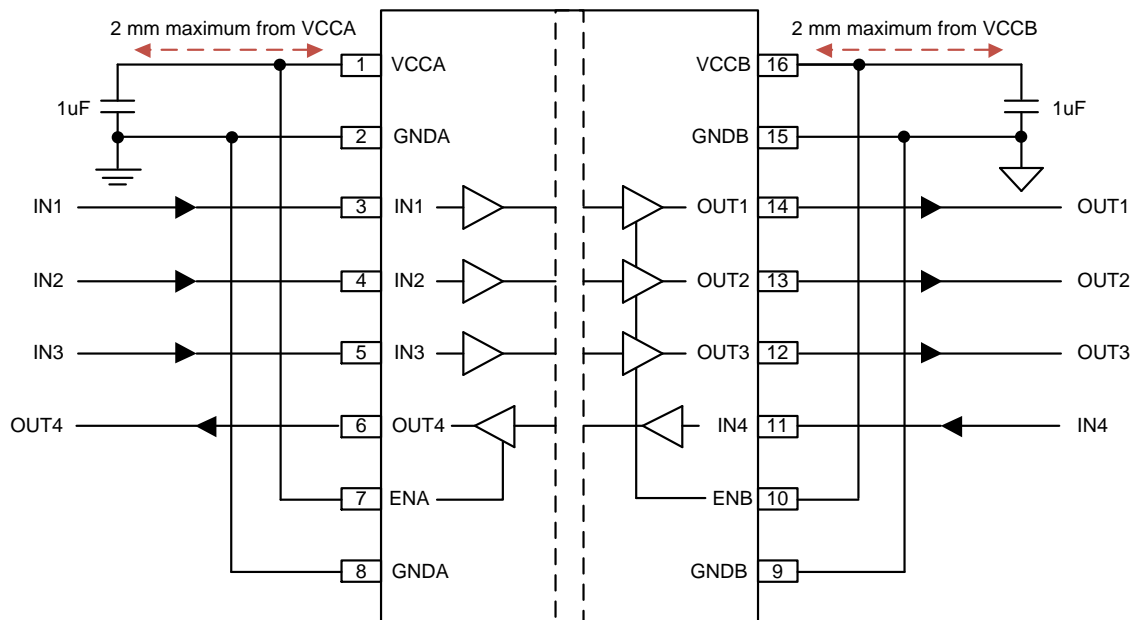
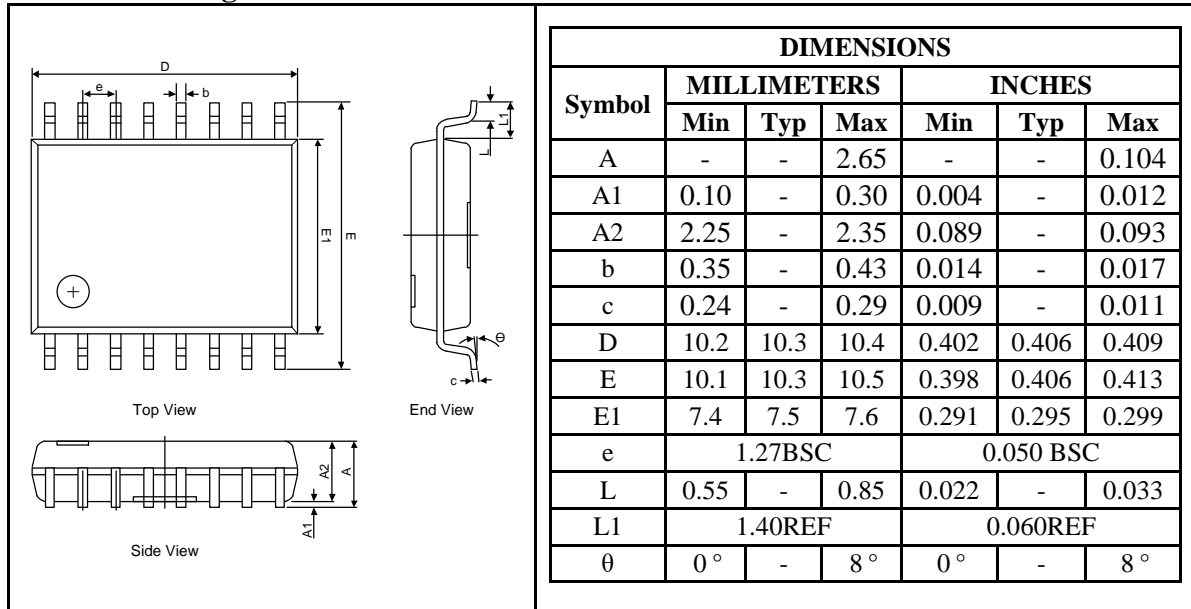

Figure 12-1. UMISO7741 Typical Application

Package Information

WSOP16

Outline Drawing



Land Pattern

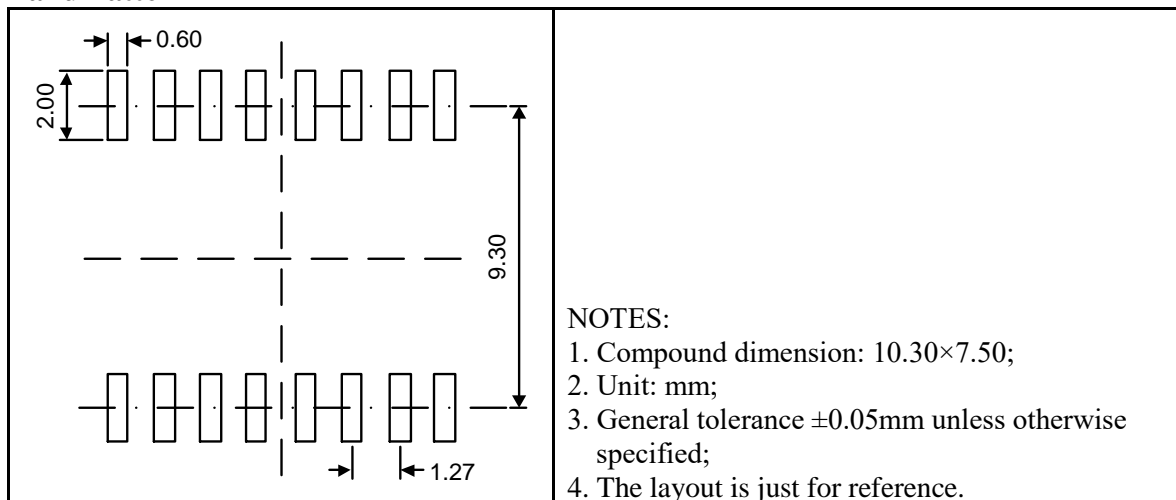

Packing Information

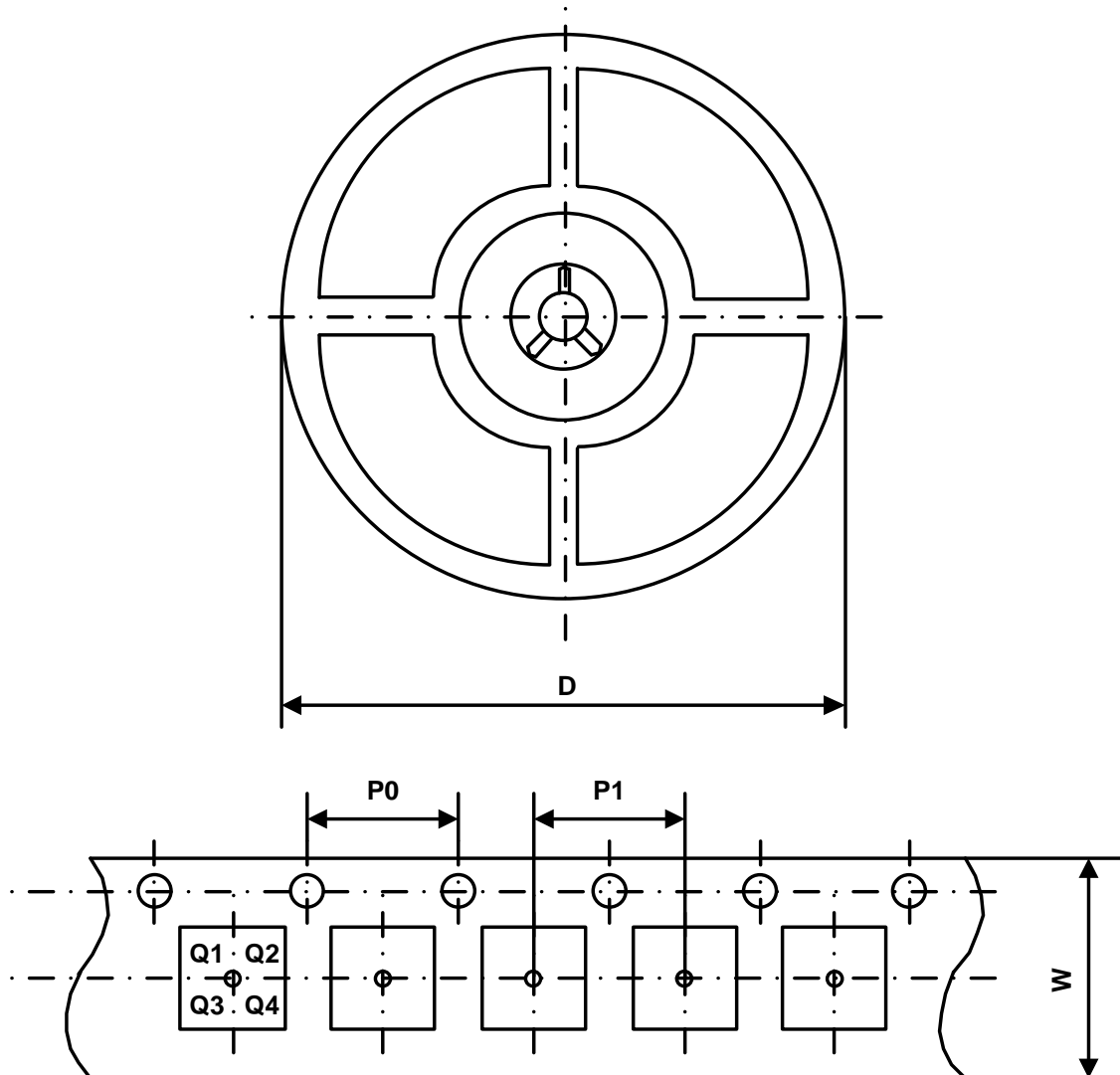

Part Number	Package Type	Carrier Width (W)	Pitch (P0)	Pitch (P1)	Reel Size (D)	PIN 1 Quadrant
UMISO7740LWSG	WSOP16	16 mm	4 mm	12 mm	330 mm	Q1
UMISO7740HWSG	WSOP16	16 mm	4 mm	12 mm	330 mm	Q1
UMISO7741LWSG	WSOP16	16 mm	4 mm	12 mm	330 mm	Q1
UMISO7741HWSG	WSOP16	16 mm	4 mm	12 mm	330 mm	Q1
UMISO7742LWSG	WSOP16	16 mm	4 mm	12 mm	330 mm	Q1
UMISO7742HWSG	WSOP16	16 mm	4 mm	12 mm	330 mm	Q1

GREEN COMPLIANCE

Union Semiconductor is committed to environmental excellence in all aspects of its operations including meeting or exceeding regulatory requirements with respect to the use of hazardous substances. Numerous successful programs have been implemented to reduce the use of hazardous substances and/or emissions.

All Union components are compliant with the RoHS directive, which helps to support customers in their compliance with environmental directives. For more green compliance information, please visit:

<https://www.union-ic.com/Quality.html>

IMPORTANT NOTICE

The information in this document has been carefully reviewed and is believed to be accurate. Nonetheless, this document is subject to change without notice. Union assumes no responsibility for any inaccuracies that may be contained in this document, and makes no commitment to update or to keep current the contained information, or to notify a person or organization of any update. Union reserves the right to make changes, at any time, in order to improve reliability, function or design and to attempt to supply the best product possible.