

高速双通道数字隔离器

UMISO7720 SOP8/WSOP8/WSOP16
UMISO7721 SOP8/WSOP8/WSOP16
UMISO7723 SOP8/WSOP8/WSOP16

1 描述

UMISO772x 系列均为高性能双通道单向数字隔离器，提供 $3.75\text{kV}_{\text{RMS}}$ （窄体封装）和 5kV_{RMS} （宽体封装）两种隔离等级，支持 DC 至 150Mbps 数据传输速率。该器件以具备低功耗的特点，同时展现出优异的电磁抗扰性和低辐射特性，可有效隔离不同接地域，并阻断高压/大电流瞬态干扰对敏感电路或人机接口电路的影响。各隔离通道均由逻辑输入与输出缓冲器构成，并通过二氧化硅（SiO₂）电容绝缘屏障实现电气隔离。每个输入端集成的施密特触发器在汽车应用中可提供卓越的抗噪性能。

UMISO7720 系列两通道都为正向传输。UMISO7721 和 UMISO7723 系列具有一路正向和一路反向通道，以适配隔离式 CAN、RS-485 等通信场景。这些器件具备默认输出特性。当电源未上电或处于开路状态时，后缀为 L 的型号默认输出低电平，后缀为 H 的型号默认输出高电平。具体型号后缀与选项的对应关系详见订购信息表。

UMISO772x 系列采用 SOP8 窄体封装、WSOP8 宽体封装和 WSOP16 宽体封装，其工作环境温度范围为 $-40\text{ }^{\circ}\text{C}$ 至 $125\text{ }^{\circ}\text{C}$ 。

2 特性

- 数据传输速率：DC至150Mbps
- 稳健的数字信号电气隔离
 - 长使用寿命：>40 年
 - 高达 $5000\text{ V}_{\text{RMS}}$ 隔离电压（宽体封装）
 - CMTI: $\pm 200\text{ kV}/\mu\text{s}$ （典型值）
- 宽电源电压范围：2.375V至5.5V
- 宽工作环境温度范围： $-40\text{ }^{\circ}\text{C}$ 至 $125\text{ }^{\circ}\text{C}$
- 封装选项：
 - SOP8窄体封装
 - WSOP8宽体封装
 - WSOP16宽体封装
- 默认输出高电平（UMISO772xH）和默认输出低电平（UMISO772xL）选项
- 高电磁抗扰度
- 免初始化启动
- 低传播延迟和偏移
 - 传播延迟：< 15ns
 - 脉冲宽度失真：< 2.6ns
- 符合安全规范
 - DIN EN IEC 60747-17 (VDE 0884-17)
 - UL1577
 - IEC 61010-1 和 GB 4943.1-2022

3 应用

- 工业自动化
- 医疗设备
- 光伏逆变器
- 电机控制
- 隔离电源
- 隔离式RS-485、CAN

4 Simplified Channel Structure

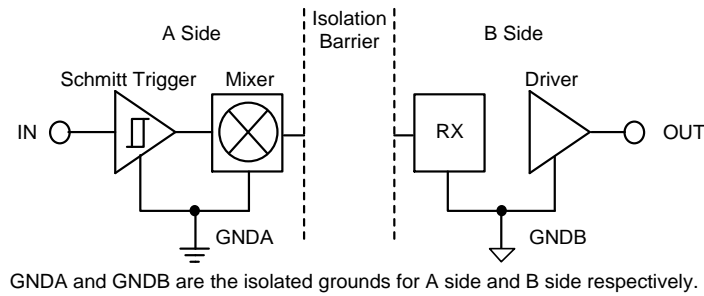

5 Ordering Information

Part Number	A Side Inputs	B Side Inputs	Default Output	Isolation Rating (V _{RMS})	Package	Shipping Qty
UMISO7720LS8	2	0	Low	3750	SOP8	3000pcs/13Inch Tape & Reel
UMISO7720LWS8	2	0	Low	5000	WSOP8	1000pcs/13Inch Tape & Reel
UMISO7720LWSG	2	0	Low	5000	WSOP16	1500pcs/13Inch Tape & Reel
UMISO7720HS8	2	0	High	3750	SOP8	3000pcs/13Inch Tape & Reel
UMISO7720HWS8	2	0	High	5000	WSOP8	1000pcs/13Inch Tape & Reel
UMISO7720HWSG	2	0	High	5000	WSOP16	1500pcs/13Inch Tape & Reel
UMISO7721LS8	1	1	Low	3750	SOP8	3000pcs/13Inch Tape & Reel
UMISO7721LWS8	1	1	Low	5000	WSOP8	1000pcs/13Inch Tape & Reel
UMISO7721LWSG	1	1	Low	5000	WSOP16	1500pcs/13Inch Tape & Reel
UMISO7721HS8	1	1	High	3750	SOP8	3000pcs/13Inch Tape & Reel
UMISO7721HWS8	1	1	High	5000	WSOP8	1000pcs/13Inch Tape & Reel
UMISO7721HWSG	1	1	High	5000	WSOP16	1500pcs/13Inch Tape & Reel
UMISO7723LS8	1	1	Low	3750	SOP8	3000pcs/13Inch Tape & Reel
UMISO7723LWS8	1	1	Low	5000	WSOP8	1000pcs/13Inch Tape & Reel
UMISO7723LWSG	1	1	Low	5000	WSOP16	1500pcs/13Inch Tape & Reel
UMISO7723HS8	1	1	High	3750	SOP8	3000pcs/13Inch Tape & Reel
UMISO7723HWS8	1	1	High	5000	WSOP8	1000pcs/13Inch Tape & Reel
UMISO7723HWSG	1	1	High	5000	WSOP16	1500pcs/13Inch Tape & Reel

6 Pin Configuration and Function

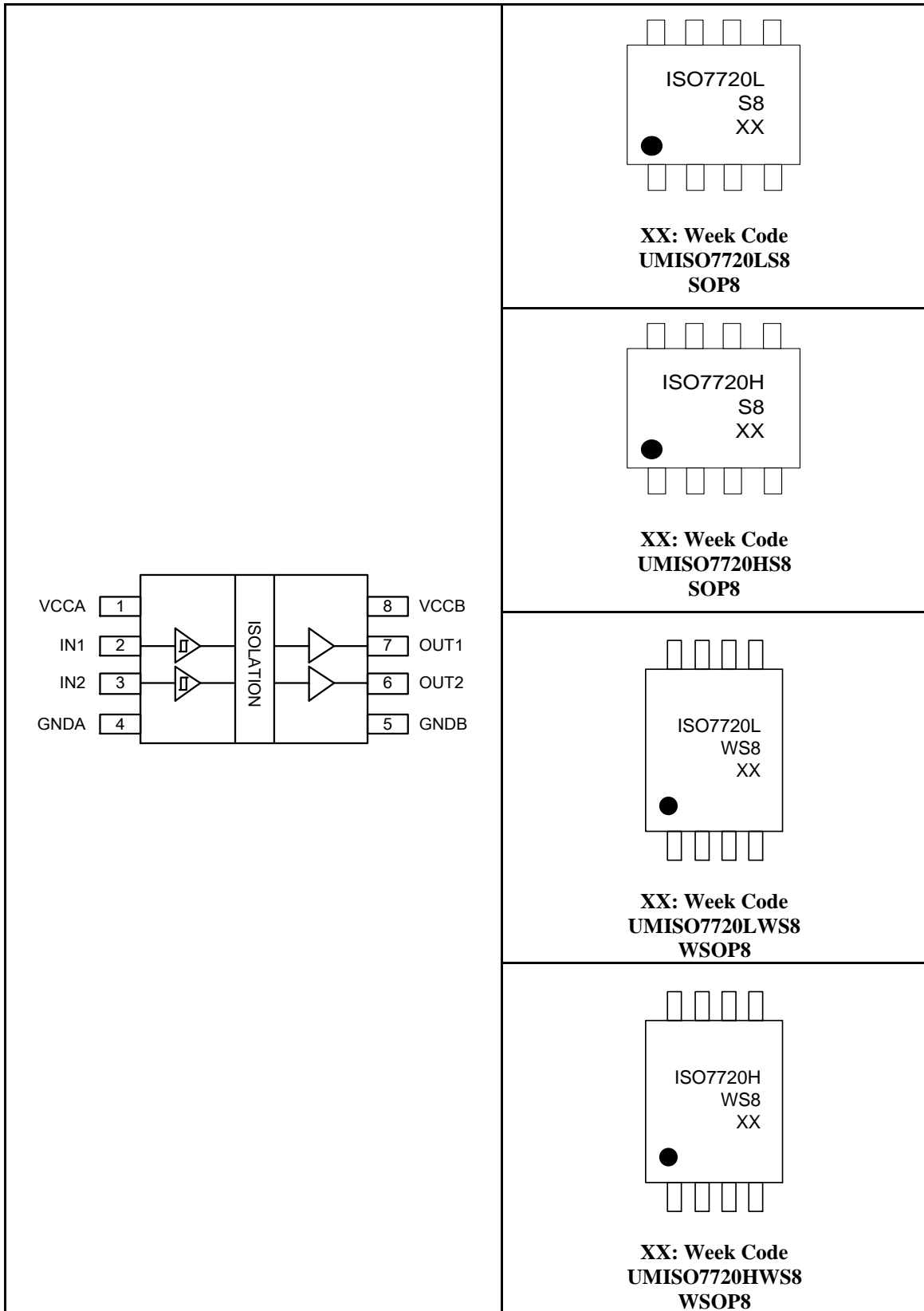

6 Pin Configuration and Function (continued)

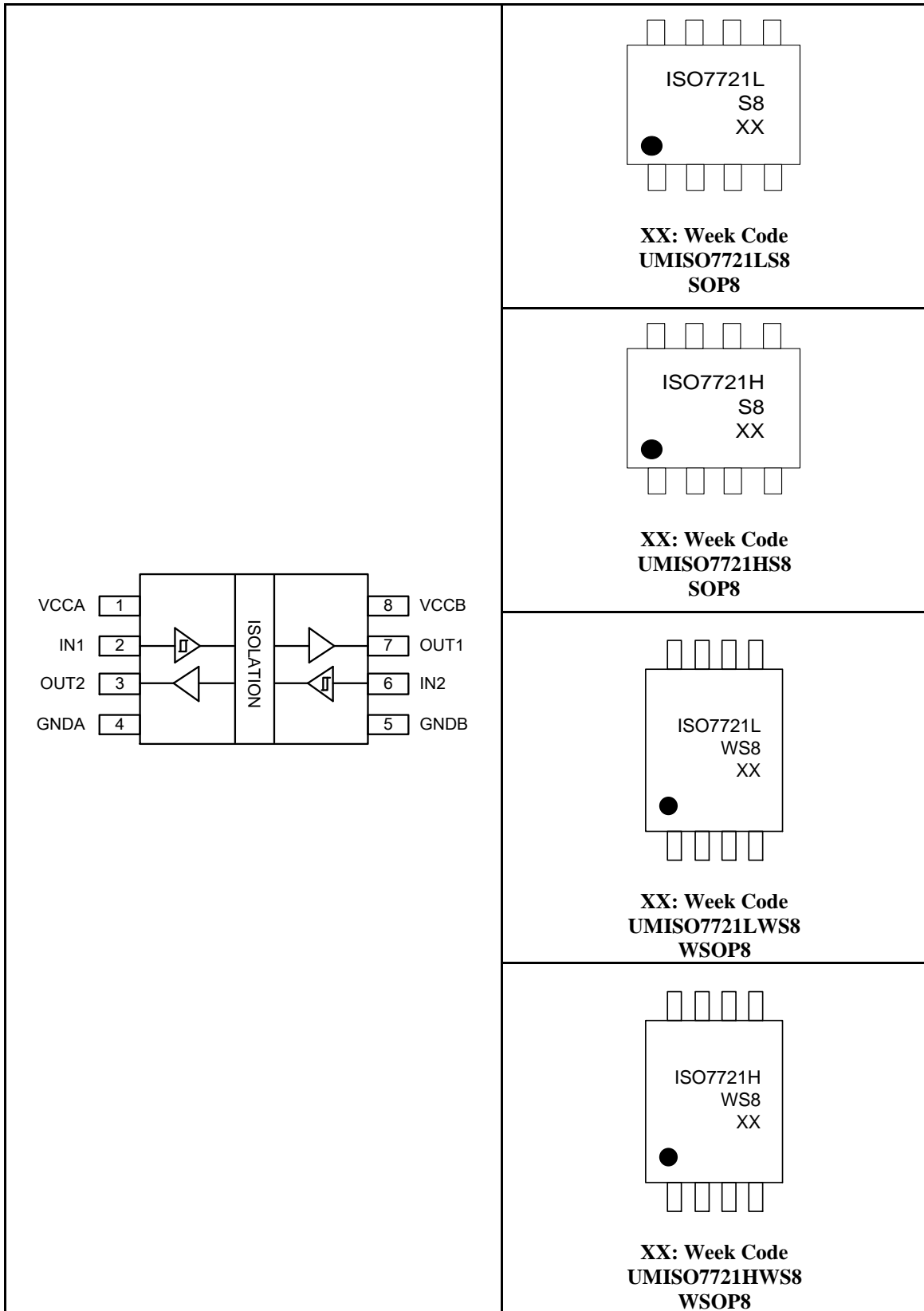

6 Pin Configuration and Function (continued)

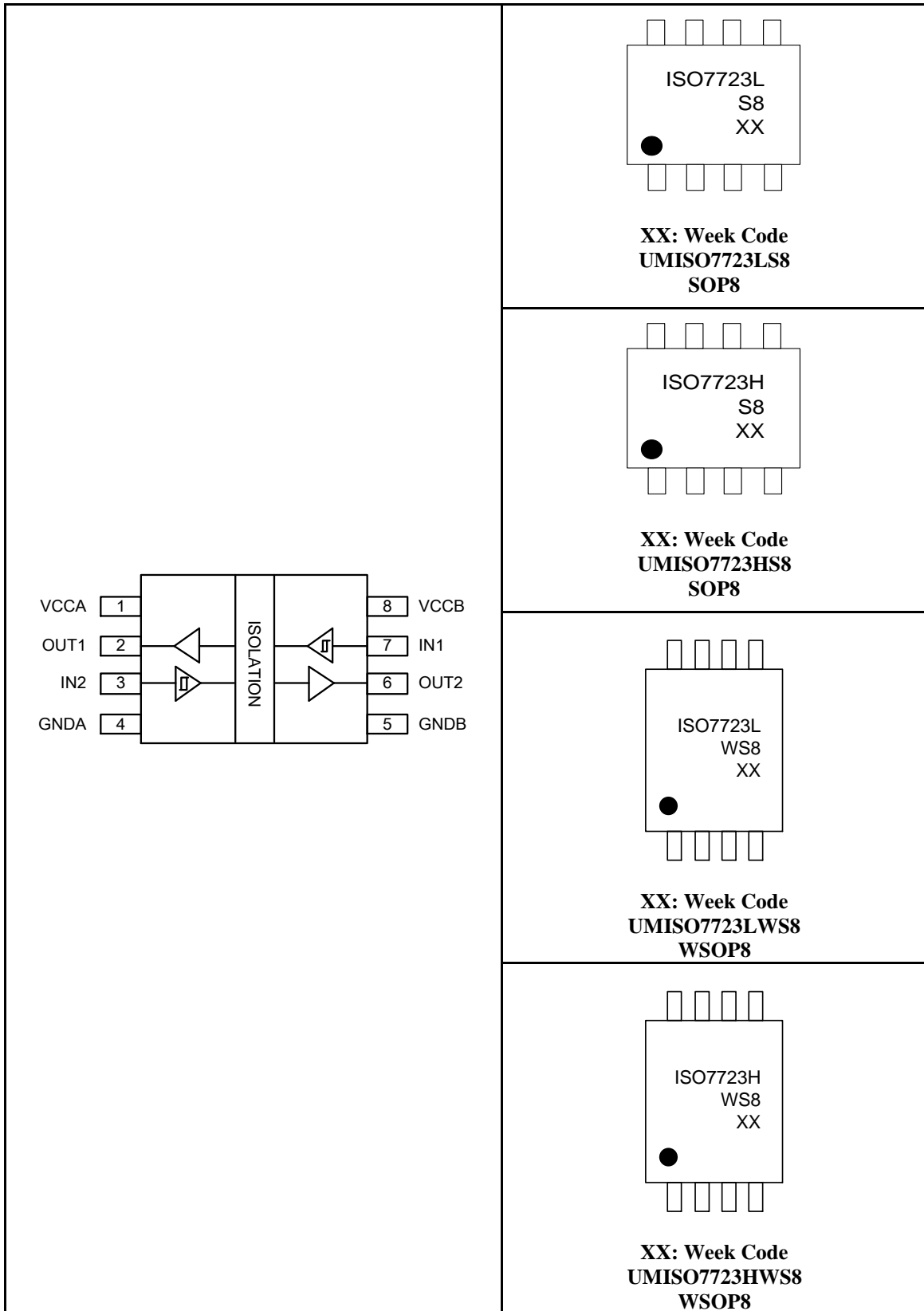

6 Pin Configuration and Function (continued)

Table 6-1. Pin functions for the UMISO772x 8-Pin SOP8 and WSOP8 packages

SOP8 and WSOP8 Pin No.			Pin Name	Function
UMISO7720	UMISO7721	UMISO7723		
1	1	1	VCCA	Power supply for isolator side A.
2	2	7	IN1	Logic input 1, corresponds to logic output 1.
3	6	3	IN2	Logic input 2, corresponds to logic output2.
4	4	4	GNDA	Ground reference for isolator side A.
5	5	5	GNDB	Ground reference for isolator side B.
7	7	2	OUT1	Logic output 1, OUT1 is the logic output for the IN1 input.
6	3	6	OUT2	Logic output 2, OUT2 is the logic output for the IN2 input.
8	8	8	VCCB	Power supply for isolator side B.

6 Pin Configuration and Function (continued)

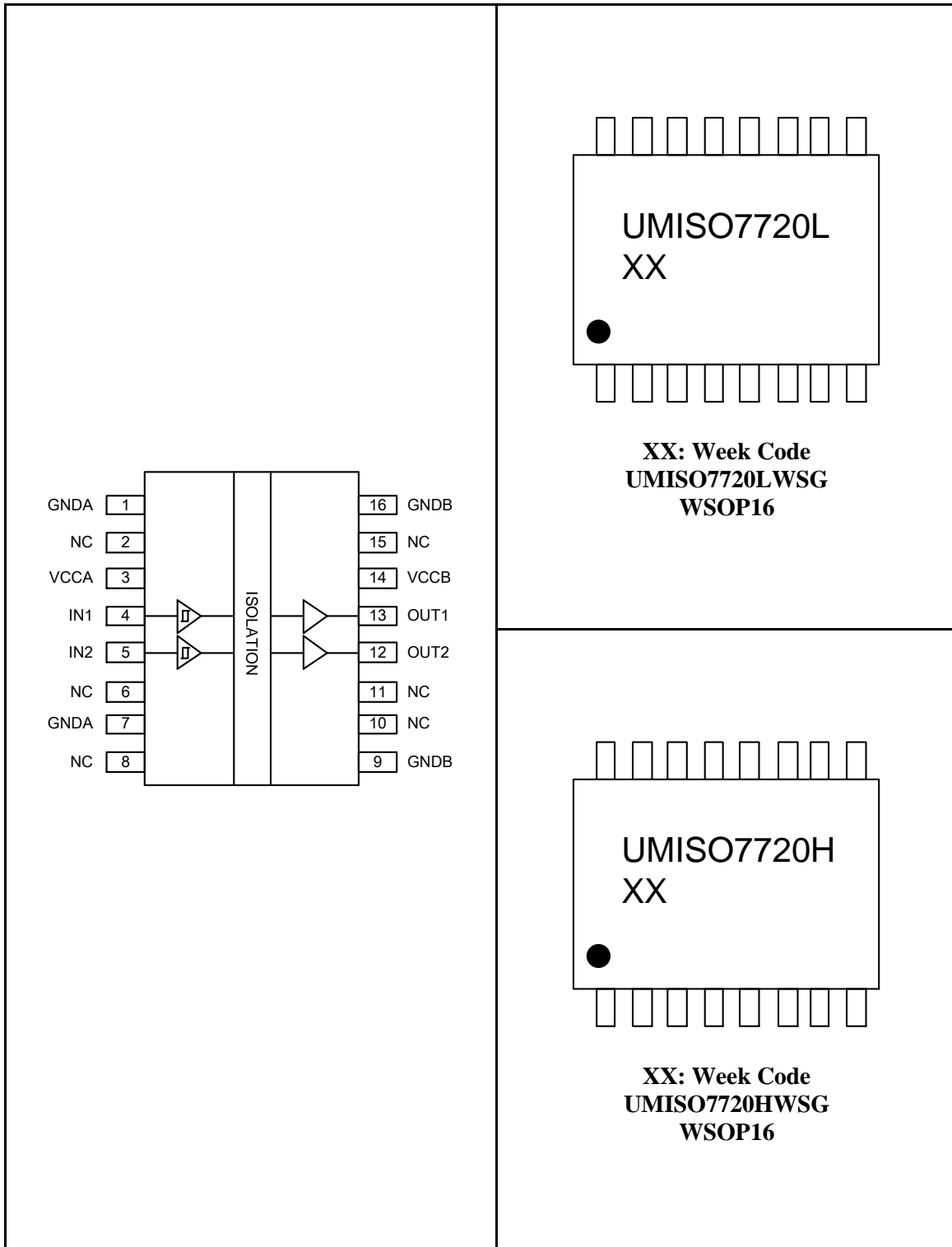

6 Pin Configuration and Function (continued)

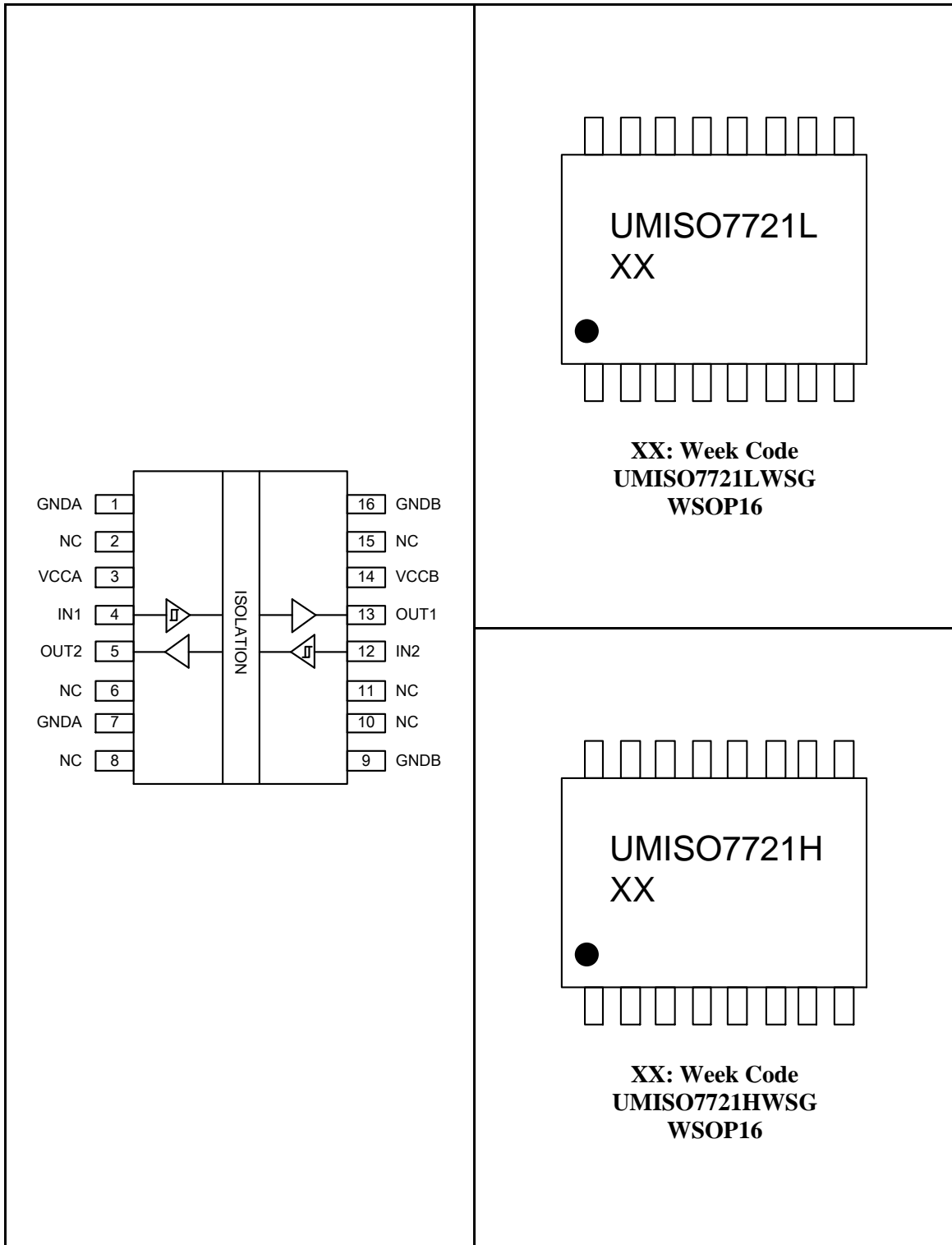

6 Pin Configuration and Function (continued)

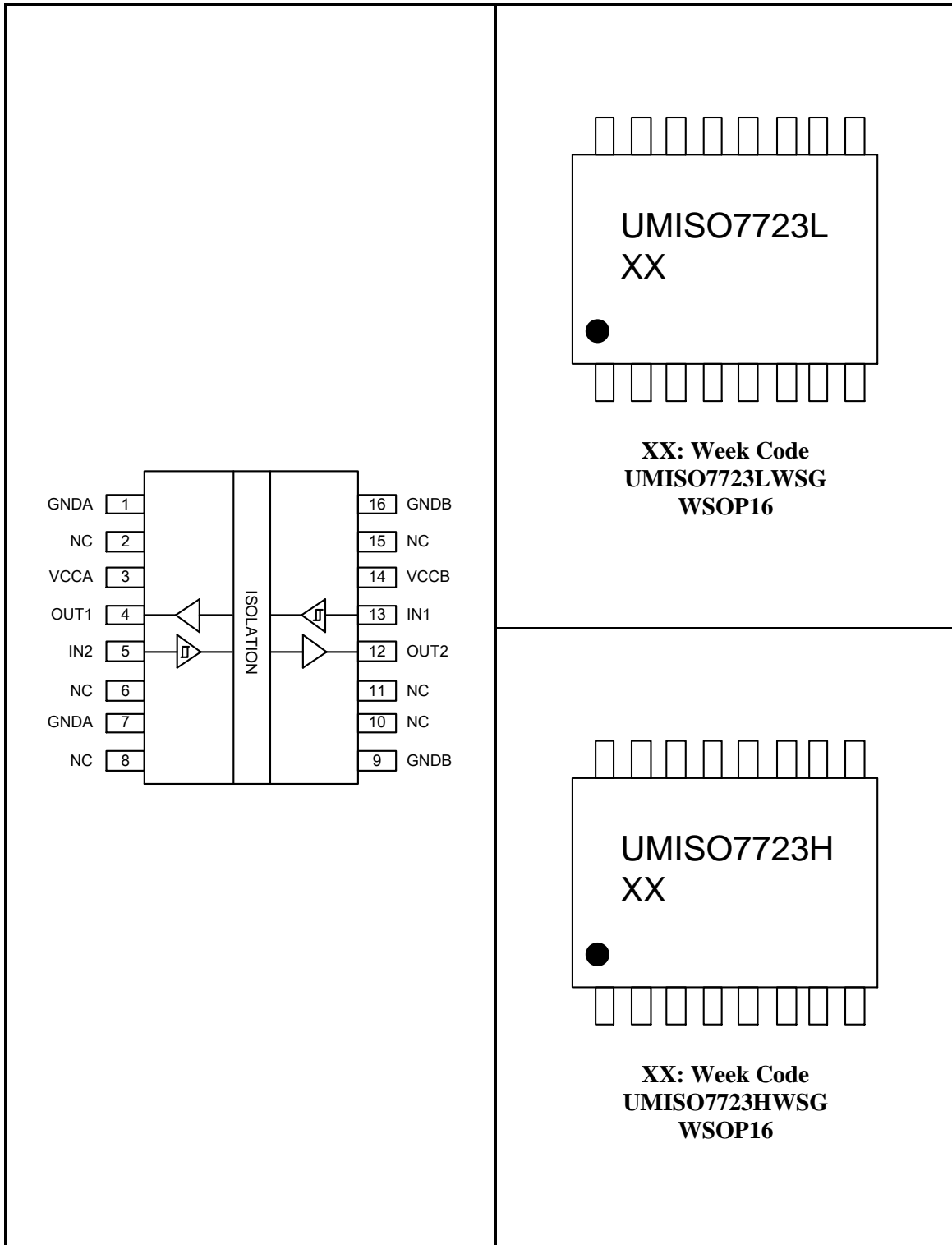

6 Pin Configuration and Function (continued)

Table 6-2. Pin functions for the UMISO772x 16-Pin WSOP16 package

WSOP16 Pin No.			Pin Name	Function
UMISO7720	UMISO7721	UMISO7723		
1, 7	1, 7	1, 7	GNDA	Ground reference for isolator side A.
2, 6, 8	2, 6, 8	2, 6, 8	NC	Not connected. They can be left floating, tied to VCCA or tied to GNDA.
3	3	3	VCCA	Power supply for isolator side A.
4	4	13	IN1	Logic input 1, corresponds to logic output 1.
5	12	5	IN2	Logic input 2, corresponds to logic output2.
10, 11, 15	10, 11, 15	10, 11, 15	NC	Not connected. They can be left floating, tied to VCCB or tied to GNDB.
9, 16	9, 16	9, 16	GNDB	Ground reference for isolator side B.
13	13	4	OUT1	Logic output 1, OUT1 is the logic output for the IN1 input.
12	5	12	OUT2	Logic output 2, OUT2 is the logic output for the IN2 input.
14	14	14	VCCB	Power supply for isolator side B.

7 Specifications

7.1 Absolute Maximum Ratings (Note 1)

Symbol	Parameter	Conditions	Min	Typ	Max	Unit
V _{CCA}	Supply voltage for isolator side A	Note 2	-0.5		6	V
V _{CCB}	Supply voltage for isolator side B	Note 2	-0.5		6	V
V _I	Voltage on IN _x , OUT _x	Note 3	-0.5		V _{CCX} +0.5	V
V _{ESD}	Human body model (HBM), per ANSI/ESDA/JEDEC JS-001	All pins		±8		kV
I _{LU}	Latch up, per JEDEC JESD78			200		mA
I _O	Output current		-15		15	mA
T _J	Junction temperature				150	°C
T _{STG}	Storage temperature		-65		150	°C

Note 1: Stresses beyond those listed under Absolute Maximum Ratings may cause permanent damage to the device. These are stress ratings only, which do not imply functional operation of the device at these or any other conditions beyond those indicated under Recommended Operating Conditions. Exposure to absolute-maximum-rated conditions for extended periods may affect device reliability.

Note 2: All voltage values are with respect to the local ground terminal (GNDA or GNDB) and are peak voltage values.

Note 3: Maximum voltage must not exceed 6 V.

7.2 Recommended Operating Conditions (Note 1)

Symbol	Parameter	Conditions	Min	Typ	Max	Unit
V _{CCA}	Supply voltage for isolator side A		2.375	3.3/5.0	5.5	V
V _{CCB}	Supply voltage for isolator side B		2.375	3.3/5.0	5.5	V
V _{CC(UVLO+)}	V _{CC} undervoltage-lockout threshold when supply voltage is rising		2	2.2	2.35	V
V _{CC(UVLO-)}	V _{CC} undervoltage-lockout threshold when supply voltage is falling		1.98	2.1	2.21	V
V _{HYS(UVLO)}	V _{CC} undervoltage-lockout threshold hysteresis		100	120	160	mV
I _{OH}	High-level output current	V _{CCO} = 5V	-4			mA
		V _{CCO} = 3.3V	-2			
		V _{CCO} = 2.5V	-1			
I _{OL}	Low-level output current	V _{CCO} = 5V			4	mA
		V _{CCO} = 3.3V			2	
		V _{CCO} = 2.5V			1	

7.2 Recommended Operating Conditions (continued)

Symbol	Parameter	Conditions	Min	Typ	Max	Unit
V _{IH}	Input High Voltage		2			V
V _{IL}	Input Low Voltage				0.8	V
DR	Data rate				150	Mbps
T _A	Ambient temperature		-40	25	125	°C

Note 1: V_{CCO} = Output-side supply V_{CC}.

7.3 Thermal Information

Symbol	Parameter	Value	Unit
R _{θJA}	Junction to ambient thermal resistance	SOP8	108
		WSOP8	90
		WSOP16	80

7.4 Power Rating

Symbol	Parameter	Conditions	Min	Typ	Max	Unit
UMISO7720						
P _D	Maximum power dissipation	V _{CCA} = V _{CBB} = 5.5 V, C _L = 15 pF, T _J = 150°C, Input a 75 MHz, 50% duty cycle square wave.			176	mW
P _{DA}	Maximum power dissipation on A side				33	mW
P _{DB}	Maximum power dissipation on B side				143	mW
UMISO7721						
P _D	Maximum power dissipation	V _{CCA} = V _{CBB} = 5.5 V, C _L = 15 pF, T _J = 150°C, Input a 75 MHz, 50% duty cycle square wave.			176	mW
P _{DA}	Maximum power dissipation on A side				88	mW
P _{DB}	Maximum power dissipation on B side				88	mW
UMISO7723						
P _D	Maximum power dissipation	V _{CCA} = V _{CBB} = 5.5 V, C _L = 15 pF, T _J = 150°C, Input a 75 MHz, 50% duty cycle square wave.			176	mW
P _{DA}	Maximum power dissipation on A side				88	mW
P _{DB}	Maximum power dissipation on B side				88	mW

7.5 Insulation Specifications

Symbol	Parameter	Conditions	Value		Unit
			SOP8	WSOP8/WSOP16	
CLR	External clearance	Shortest terminal-to-terminal distance through air	4	8	mm
CPG	External creepage	Shortest terminal-to-terminal distance across the package surface	4	8	mm
DTI	Distance through the insulation	Minimum internal gap (internal clearance)	16	16	μm
CTI	Comparative tracking index	DIN EN 60112 (VDE 0303-11); IEC 60112	>600	>600	V
	Material group	Per IEC 60664-1	I	I	
	Overvoltage category per IEC 60664-1	Rated mains voltage ≤ 150 V _{RMS}	I-IV	I-IV	
		Rated mains voltage ≤ 300 V _{RMS}	I-III	I-IV	
		Rated mains voltage ≤ 600 V _{RMS}	N/A	I-IV	
		Rated mains voltage ≤ 1000 V _{RMS}	N/A	I-II	
DIN V VDE V 0884-17:2021-10 (Note 1)					
V _{IORM}	Maximum repetitive peak isolation voltage	AC voltage (bipolar)	637	1414	V _{PK}
V _{IOWM}	Maximum operating isolation voltage	AC voltage; time-dependent dielectric breakdown (TDDb) test	450	1000	V _{RMS}
		DC voltage	637	1414	V _{DC}
V _{IOTM}	Maximum transient isolation voltage	V _{TEST} = V _{IOTM} , t = 60 s (certified); V _{TEST} = 1.2 × V _{IOTM} , t = 1 s (100% product test)	5300	7070	V _{PK}
V _{IMP}	Maximum impulse voltage	Tested in air, 1.2/50 μs waveform per IEC 62368-1,	5000	6000	V _{PK}
V _{IOSM}	Maximum surge isolation voltage	V _{IOSM} ≥ 1.3 × V _{IMP} ; Tested in oil (qualification test), 1.2/50 μs waveform per IEC 62368-1	6500	8000	V _{PK}

7.5 Insulation Specifications (continued)

Symbol	Parameter	Conditions	Value		Unit
			SOP8	WSOP8/WSOP16	
Q _{pd}	Apparent charge (Note 2)	Method a, after input/output safety test of the subgroup 2/3, $V_{ini} = V_{IOTM}$, $t_{ini} = 60$ s; $V_{pd(m)} = 1.2 \times V_{IORM}$, $t_m = 10$ s	≤5	≤5	pC
		Method a, after environmental test of the subgroup 1, $V_{ini} = V_{IOTM}$, $t_{ini} = 60$ s; $V_{pd(m)} = 1.3 \times V_{IORM}$, $t_m = 10$ s	≤5	≤5	pC
		Method b, at routine test (100% production test) and preconditioning (type test) $V_{ini} = 1.2 \times V_{IOTM}$, $t_{ini} = 1$ s; $V_{pd(m)} = 1.5 \times V_{IORM}$, $t_m = 1$ s (method b1) or $V_{pd(m)} = V_{ini}$, $t_m = t_{ini}$ (method b2)	≤5	≤5	pC
C _{IO}	Barrier capacitance, input to output (Note 3)	$V_{IO} = 0.4 \times \sin(2\pi ft)$, $f = 1$ MHz	~1.0	~1.0	pF
R _{IO}	Isolation resistance (Note 3)	$V_{IO} = 500$ V, $T_A = 25$ °C	>10 ¹²	>10 ¹²	Ω
		$V_{IO} = 500$ V, 100 °C ≤ T_A ≤ 125 °C	>10 ¹¹	>10 ¹¹	
		$V_{IO} = 500$ V at $T_s = 150$ °C	>10 ⁹	>10 ⁹	
	Pollution degree		2	2	
UL 1577					
V _{ISO}	Maximum withstanding isolation voltage	$V_{TEST} = V_{ISO}$, $t = 60$ s (qualification) $V_{TEST} = 1.2 \times V_{ISO}$, $t = 1$ s (100% production test)	3750	5000	V _{RMS}

Note 1: This coupler is suitable for “safe electrical insulation” only within the safety ratings.

Compliance with the safety ratings shall be ensured by means of suitable protective circuits.

Note 2: The characterization charge is discharging charge (pd) caused by partial discharge.

Note 3: Capacitance and resistance are measured with all pins on field-side and logic-side tied together.

7.6 Electrical Characteristics

7.6.1 Electrical Characteristics ($V_{CCA} = V_{CCB} = 5\text{ V} \pm 10\%$)

$V_{CCA} = V_{CCB} = 5\text{ V} \pm 10\%$, $T_A = -40$ to 125°C (over recommended operating conditions, unless otherwise specified).

Symbol	Parameter	Conditions	Min	Typ	Max	Unit
V_{OH}	Output high voltage	$I_{OH} = -4\text{ mA}$ (Note 1)	$V_{CCO} - 0.4$	4.8		V
V_{OL}	Output low voltage	$I_{OL} = 4\text{ mA}$		0.2	0.4	V
$V_{IT+(IN)}$	Logic input high		2.0			V
$V_{IT-(IN)}$	Logic input low				0.8	V
I_{IH}	High-level input leakage current	$V_{IH} = V_{CCA}$ at IN_x			20	μA
I_{IL}	Low-level input leakage current	$V_{IL} = 0\text{V}$ at IN_x	-20			μA
Z_O	Output impedance			50		Ω
CMTI Immunity	Common-mode transient	$V_I = V_{CC1}$ or 0 V , $V_{CM} = 1200\text{ V}$, See Figure 8-3 (Note 1)	150	200		$\text{kV}/\mu\text{s}$
C_I	Input capacitance (Note 2)	$V_I = V_{CC}/2 + 0.4 \times \sin(2\pi ft)$, $f = 1\text{ MHz}$, $V_{CC} = 5\text{ V}$		2		pF

7.6.2 Electrical Characteristics ($V_{CCA} = V_{CCB} = 3.3\text{ V} \pm 10\%$)

$V_{CCA} = V_{CCB} = 3.3\text{ V} \pm 10\%$, $T_A = -40$ to 125°C (over recommended operating conditions, unless otherwise specified).

Symbol	Parameter	Conditions	Min	Typ	Max	Unit
V_{OH}	Output high voltage	$I_{OH} = -2\text{ mA}$ (Note 1)	$V_{CCO} - 0.4$	3.2		V
V_{OL}	Output low voltage	$I_{OL} = 2\text{ mA}$		0.1	0.4	V
$V_{IT+(IN)}$	Logic input high		2.0			V
$V_{IT-(IN)}$	Logic input low				0.8	V
I_{IH}	High-level input leakage current	$V_{IH} = V_{CCA}$ at IN_x			20	μA
I_{IL}	Low-level input leakage current	$V_{IL} = 0\text{V}$ at IN_x	-20			μA
Z_O	Output impedance			50		Ω
CMTI Immunity	Common-mode transient	$V_I = V_{CC1}$ or 0 V , $V_{CM} = 1200\text{ V}$, See Figure 8-3 (Note 1)	150	200		$\text{kV}/\mu\text{s}$
C_I	Input capacitance (Note 2)	$V_I = V_{CC}/2 + 0.4 \times \sin(2\pi ft)$, $f = 1\text{ MHz}$, $V_{CC} = 3.3\text{ V}$		2		pF

7.6.3 Electrical Characteristics ($V_{CCA} = V_{CCB} = 2.5\text{ V} \pm 5\%$)

$V_{CCA} = V_{CCB} = 2.5\text{ V} \pm 5\%$, $T_A = -40$ to 125°C (over recommended operating conditions, unless otherwise specified).

Symbol	Parameter	Conditions	Min	Typ	Max	Unit
V_{OH}	Output high voltage	$I_{OH} = -1\text{ mA}$ (Note 1)	$V_{CCO} - 0.4$	2.45		V
V_{OL}	Output low voltage	$I_{OL} = 1\text{ mA}$		0.05	0.4	V
$V_{IT+(IN)}$	Logic input high		2.0			V
$V_{IT-(IN)}$	Logic input low				0.8	V
I_{IH}	High-level input leakage current	$V_{IH} = V_{CCA}$ at IN_x			20	μA
I_{IL}	Low-level input leakage current	$V_{IL} = 0\text{V}$ at IN_x	-20			μA
Z_O	Output impedance			50		Ω
CMTI Immunity	Common-mode transient	$V_I = V_{CCI}$ or 0 V , $V_{CM} = 1200\text{ V}$, See Figure 8-3 (Note 1)	150	200		$\text{kV}/\mu\text{s}$
C_I	Input capacitance (Note 2)	$V_I = V_{CC}/2 + 0.4 \times \sin(2\pi ft)$, $f = 1\text{ MHz}$, $V_{CC} = 2.5\text{ V}$		2		pF

Note 1: V_{CCI} = Input-side supply V_{CC} , V_{CCO} = Output-side supply V_{CC} .

Note 2: Measured from pin to Ground.

7.7 Supply Current Characteristics

7.7.1 Supply Current Characteristics ($V_{CCA} = V_{CCB} = 5\text{ V} \pm 10\%$) (Note 1)

$V_{CCA} = V_{CCB} = 5\text{ V} \pm 10\%$, $T_A = -40$ to 125°C (over recommended operating conditions, unless otherwise specified).

Symbol	Parameter	Conditions	Min	Typ	Max	Unit			
UMISO7720									
I_{CCA}	Supply Current - DC signal	$V_{IN} = 0\text{V}$ (UMISO7720L); $V_{IN} = V_{CCI}$ (UMISO7720H)		1.5	3.4	mA			
I_{CCB}				3.0	5.0				
I_{CCA}		$V_{IN} = V_{CCI}$ (UMISO7720L); $V_{IN} = 0\text{V}$ (UMISO7720H)		6.1	8.3				
I_{CCB}				3.0	5.0				
I_{CCA}	Supply Current - AC signal	All channels switching with 50% duty cycle square wave clock input with 5V amplitude; $C_L = 15\text{ pF}$ for each channel.	1Mbps		3.7		6.7		
I_{CCB}					3.3		6.7		
I_{CCA}			10Mbps		3.7		7.1		
I_{CCB}					4.3		7.5		
I_{CCA}			100Mbps		4.1		7.2		
I_{CCB}					13.8		20.1		
UMISO7721									
I_{CCA}			Supply Current - DC signal	$V_{IN} = 0\text{V}$ (UMISO7721L); $V_{IN} = V_{CCI}$ (UMISO7721H)			2.3	4.0	mA
I_{CCB}		2.3			4.0				
I_{CCA}	$V_{IN} = V_{CCI}$ (UMISO7721L); $V_{IN} = 0\text{V}$ (UMISO7721H)			4.6	6.6				
I_{CCB}				4.6	6.6				
I_{CCA}	Supply Current - AC signal	All channels switching with 50% duty cycle square wave clock input with 5V amplitude; $C_L = 15\text{ pF}$ for each channel.	1Mbps		3.5	6.7			
I_{CCB}					3.5	6.7			
I_{CCA}			10Mbps		3.8	7.2			
I_{CCB}					3.8	7.2			
I_{CCA}			100Mbps		7.0	13.5			
I_{CCB}					7.6	14.1			
UMISO7723									
I_{CCA}	Supply Current - DC signal	$V_{IN} = 0\text{V}$ (UMISO7723L); $V_{IN} = V_{CCI}$ (UMISO7723H)		2.2	4.3	mA			
I_{CCB}				2.2	4.3				
I_{CCA}		$V_{IN} = V_{CCI}$ (UMISO7723L); $V_{IN} = 0\text{V}$ (UMISO7723H)		4.5	6.6				
I_{CCB}				4.5	6.6				
I_{CCA}	Supply Current - AC signal	All channels switching with 50% duty cycle square wave clock input with 5V amplitude; $C_L = 15\text{ pF}$ for each channel.	1Mbps		3.6		6.7		
I_{CCB}					3.6		6.7		
I_{CCA}			10Mbps		3.9		7.2		
I_{CCB}					3.9		7.2		
I_{CCA}			100Mbps		6.8		13.5		
I_{CCB}					7.1		14.1		

Note 1: V_{CCI} = Input-side supply V_{CC}

7.7.2 Supply Current Characteristics ($V_{CCA} = V_{CCB} = 3.3\text{ V} \pm 10\%$) (Note 1)

$V_{CCA} = V_{CCB} = 3.3\text{ V} \pm 10\%$, $T_A = -40$ to 125°C (over recommended operating conditions, unless otherwise specified).

Symbol	Parameter	Conditions	Min	Typ	Max	Unit	
UMISO7720							
I_{CCA}	Supply Current - DC signal	$V_{IN} = 0\text{V}$ (UMISO7720L); $V_{IN} = V_{CCI}$ (UMISO7720H)		1.4	3.4	mA	
I_{CCB}				2.8	4.9		
I_{CCA}		$V_{IN} = V_{CCI}$ (UMISO7720L); $V_{IN} = 0\text{V}$ (UMISO7720H)		6.0	8.2		
I_{CCB}				2.9	4.9		
I_{CCA}	Supply Current - AC signal	All channels switching with 50% duty cycle square wave clock input with 3.3V amplitude; $C_L = 15\text{ pF}$ for each channel.	1Mbps		3.6		6.6
I_{CCB}					3.1		6.6
I_{CCA}			10Mbps		3.6		7.1
I_{CCB}					3.8		7.1
I_{CCA}			100Mbps		4.1		7.2
I_{CCB}					10.1		15.8
UMISO7721							
I_{CCA}	Supply Current - DC signal	$V_{IN} = 0\text{V}$ (UMISO7721L); $V_{IN} = V_{CCI}$ (UMISO7721H)		2.2	3.9		mA
I_{CCB}				2.2	3.9		
I_{CCA}		$V_{IN} = V_{CCI}$ (UMISO7721L); $V_{IN} = 0\text{V}$ (UMISO7721H)		4.5	6.4		
I_{CCB}				4.5	6.4		
I_{CCA}	Supply Current - AC signal	All channels switching with 50% duty cycle square wave clock input with 3.3V amplitude; $C_L = 15\text{ pF}$ for each channel.	1Mbps		3.5	6.6	
I_{CCB}					3.5	6.6	
I_{CCA}			10Mbps		3.7	7.1	
I_{CCB}					3.7	7.1	
I_{CCA}			100Mbps		5.7	12.8	
I_{CCB}					6.1	12.8	
UMISO7723							
I_{CCA}	Supply Current - DC signal	$V_{IN} = 0\text{V}$ (UMISO7723L); $V_{IN} = V_{CCI}$ (UMISO7723H)		2.1	4.0	mA	
I_{CCB}				2.1	4.0		
I_{CCA}		$V_{IN} = V_{CCI}$ (UMISO7723L); $V_{IN} = 0\text{V}$ (UMISO7723H)		4.5	6.4		
I_{CCB}				4.5	6.4		
I_{CCA}	Supply Current - AC signal	All channels switching with 50% duty cycle square wave clock input with 3.3V amplitude; $C_L = 15\text{ pF}$ for each channel.	1Mbps		3.5		6.6
I_{CCB}					3.5		6.6
I_{CCA}			10Mbps		3.7		7.1
I_{CCB}					3.7		7.1
I_{CCA}			100Mbps		5.7		12.8
I_{CCB}					6.1		12.8

Note 1: V_{CCI} = Input-side supply V_{CC}

7.7.3 Supply Current Characteristics ($V_{CCA} = V_{CCB} = 2.5\text{ V} \pm 5\%$) (Note 1)

$V_{CCA} = V_{CCB} = 2.5\text{ V} \pm 5\%$, $T_A = -40$ to 125°C (over recommended operating conditions, unless otherwise specified).

Symbol	Parameter	Conditions	Min	Typ	Max	Unit	
UMISO7720							
I_{CCA}	Supply Current - DC signal	$V_{IN} = 0\text{V}$ (UMISO7720L); $V_{IN} = V_{CCI}$ (UMISO7720H)		1.3	3.3	mA	
I_{CCB}				2.8	4.8		
I_{CCA}		$V_{IN} = V_{CCI}$ (UMISO7720L); $V_{IN} = 0\text{V}$ (UMISO7720H)		6.0	8.2		
I_{CCB}				2.8	4.8		
I_{CCA}	Supply Current - AC signal	All channels switching with 50% duty cycle square wave clock input with 2.5V amplitude; $C_L = 15\text{ pF}$ for each channel.	1Mbps		3.6		6.6
I_{CCB}					3.1		6.6
I_{CCA}			10Mbps		3.6		7.1
I_{CCB}					3.6		7.1
I_{CCA}			100Mbps		3.8		7.1
I_{CCB}					8.4		12.3
UMISO7721							
I_{CCA}	Supply Current - DC signal	$V_{IN} = 0\text{V}$ (UMISO7721L); $V_{IN} = V_{CCI}$ (UMISO7721H)		2.2	3.9		mA
I_{CCB}				2.2	3.9		
I_{CCA}		$V_{IN} = V_{CCI}$ (UMISO7721L); $V_{IN} = 0\text{V}$ (UMISO7721H)		4.5	6.4		
I_{CCB}				4.5	6.4		
I_{CCA}	Supply Current - AC signal	All channels switching with 50% duty cycle square wave clock input with 2.5V amplitude; $C_L = 15\text{ pF}$ for each channel.	1Mbps		3.4	6.6	
I_{CCB}					3.4	6.6	
I_{CCA}			10Mbps		3.6	7.1	
I_{CCB}					3.6	7.1	
I_{CCA}			100Mbps		5.4	11.2	
I_{CCB}					5.6	11.2	
UMISO7723							
I_{CCA}	Supply Current - DC signal	$V_{IN} = 0\text{V}$ (UMISO7723L); $V_{IN} = V_{CCI}$ (UMISO7723H)		2.1	4.0	mA	
I_{CCB}				2.1	4.0		
I_{CCA}		$V_{IN} = V_{CCI}$ (UMISO7723L); $V_{IN} = 0\text{V}$ (UMISO7723H)		4.5	6.4		
I_{CCB}				4.5	6.4		
I_{CCA}	Supply Current - AC signal	All channels switching with 50% duty cycle square wave clock input with 2.5V amplitude; $C_L = 15\text{ pF}$ for each channel.	1Mbps		3.5		6.6
I_{CCB}					3.5		6.6
I_{CCA}			10Mbps		3.6		7.1
I_{CCB}					3.6		7.1
I_{CCA}			100Mbps		5.4		11.2
I_{CCB}					5.6		11.2

Note 1: V_{CCI} = Input-side supply V_{CC}

7.8 Electrical Characteristics (Dynamic)

7.8.1 Electrical Characteristics (Dynamic) ($V_{CCA} = V_{CCB} = 5\text{ V} \pm 10\%$)

$V_{CCA} = V_{CCB} = 5\text{ V} \pm 10\%$, $T_A = -40$ to 125°C (over recommended operating conditions, unless otherwise specified).

Symbol	Parameter	Conditions	Min	Typ	Max	Unit
DR	Data rate				150	Mbps
PWM_{MIN}	Minimum pulse width				5	ns
t_{PLH}	Propagation delay time	see Figure 8-1	4.5	8	16	ns
t_{PHL}		see Figure 8-1	4.5	8	16	ns
PWD	Pulse width distortion, $ t_{PLH} - t_{PHL} $	see Figure 8-1			2.6	ns
$t_{SK(O)}$	Channel-to-Channel output skew time (Note 1)	Same-direction			2.6	ns
$t_{SK(PP)}$	Part-to-Part output skew time (Note 2)			2.2	5	ns
t_R	Output signal rise time	see Figure 8-1		1	3	ns
t_F	Output signal fall time	see Figure 8-1		1	3	ns
t_{DO}	Default output delay time from input power loss	see Figure 8-2		60	70	μs
t_{SU}	Start-up time			12	20	μs

Note 1: $t_{SK(O)}$ is the skew between outputs of a single device with all driving inputs connected together and the outputs switching in the same direction while driving identical loads.

Note 2: $t_{SK(PP)}$ is the magnitude of the difference in propagation delay times between any terminals of different devices switching in the same direction while operating at identical supply voltages, temperature, input signals and loads.

7.8.2 Electrical Characteristics (Dynamic) ($V_{CCA} = V_{CCB} = 3.3 \text{ V} \pm 10\%$)
 $V_{CCA} = V_{CCB} = 3.3 \text{ V} \pm 10\%$, $T_A = -40$ to 125°C (over recommended operating conditions, unless otherwise specified).

Symbol	Parameter	Conditions	Min	Typ	Max	Unit
DR	Data rate				150	Mbps
PWM_{MIN}	Minimum pulse width				5	ns
t_{PLH}	Propagation delay time	see Figure 8-1	4.5	8	16	ns
t_{PHL}		see Figure 8-1	4.5	8	16	ns
PWD	Pulse width distortion, $ t_{PLH} - t_{PHL} $	see Figure 8-1			2.6	ns
$t_{SK(O)}$	Channel-to-Channel output skew time (Note 1)	Same-direction channels			2.6	ns
$t_{SK(PP)}$	Part-to-Part output skew time (Note 2)			2.2	5	ns
t_R	Output signal rise time	see Figure 8-1		1	3.5	ns
t_F	Output signal fall time	see Figure 8-1		1	3.5	ns
t_{DO}	Default output delay time from input power loss	see Figure 8-2		60	70	μs
t_{SU}	Start-up time			12	20	μs

Note 1: $t_{SK(O)}$ is the skew between outputs of a single device with all driving inputs connected together and the outputs switching in the same direction while driving identical loads.

Note 2: $t_{SK(PP)}$ is the magnitude of the difference in propagation delay times between any terminals of different devices switching in the same direction while operating at identical supply voltages, temperature, input signals and loads.

7.8.3 Electrical Characteristics (Dynamic) ($V_{CCA} = V_{CCB} = 2.5\text{ V} \pm 5\%$)
 $V_{CCA} = V_{CCB} = 2.5\text{ V} \pm 5\%$, $T_A = -40$ to 125°C (over recommended operating conditions, unless otherwise specified).

Symbol	Parameter	Conditions	Min	Typ	Max	Unit
DR	Data rate				150	Mbps
PWM _{MIN}	Minimum pulse width				5	ns
t _{PLH}	Propagation delay time	see Figure 8-1	5	10	18	ns
t _{PHL}		see Figure 8-1	5	10	18	ns
PWD	Pulse width distortion, $ t_{PLH} - t_{PHL} $	see Figure 8-1			2.6	ns
t _{SK(O)}	Channel-to-Channel output skew time (Note 1)	Same-direction channels			2.6	ns
t _{SK(PP)}	Part-to-Part output skew time (Note 2)			2.2	5	ns
t _R	Output signal rise time	see Figure 8-1		2	4	ns
t _F	Output signal fall time	see Figure 8-1		2	4	ns
t _{DO}	Default output delay time from input power loss	see Figure 8-2		60	70	μs
t _{SU}	Start-up time			12	20	μs

Note 1: t_{SK(O)} is the skew between outputs of a single device with all driving inputs connected together and the outputs switching in the same direction while driving identical loads.

Note 2: t_{SK(PP)} is the magnitude of the difference in propagation delay times between any terminals of different devices switching in the same direction while operating at identical supply voltages, temperature, input signals and loads.

8 Parameter Measurement Information

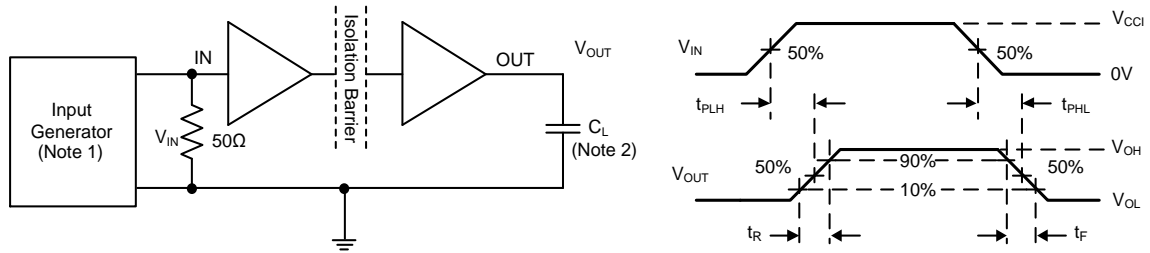

Note 1: A square wave generator provides V_{IN} input signal with characteristics: frequency $\leq 100\text{kHz}$, 50% duty cycle, $t_R \leq 3\text{ns}$, $t_F \leq 3\text{ns}$, $Z_{OUT} = 50\Omega$. At the input, 50Ω resistor is required to terminate input generator signal. It is not needed in actual application.

Note 2: $C_L = 15\text{pF}$ and includes external circuit (instrumentation and fixture etc.) capacitance. Since the load capacitance influence the output rising time, it's a key factor in the timing characteristic measurement.

Figure 8-1. Switching Characteristics Test Circuit and Voltage Waveforms

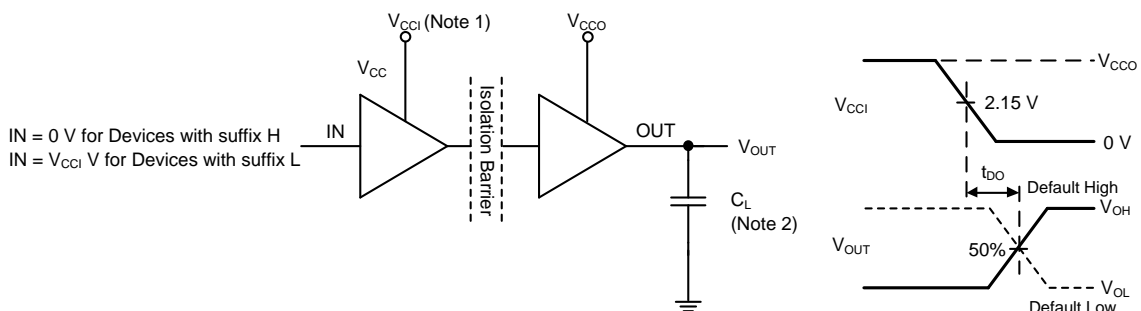

Note 1: Power Supply Ramp Rate = 10mV/ns . V_{CCI} should ramp over 2.375V , and less than 5.5V .

Note 2: $C_L = 15\text{pF}$ and includes external circuit (instrumentation and fixture etc.) capacitance. Since the load capacitance influence the output rising time, it's a key factor in the timing characteristic measurement.

Figure 8-2. Default Output Delay Time Test Circuit and Voltage Waveforms

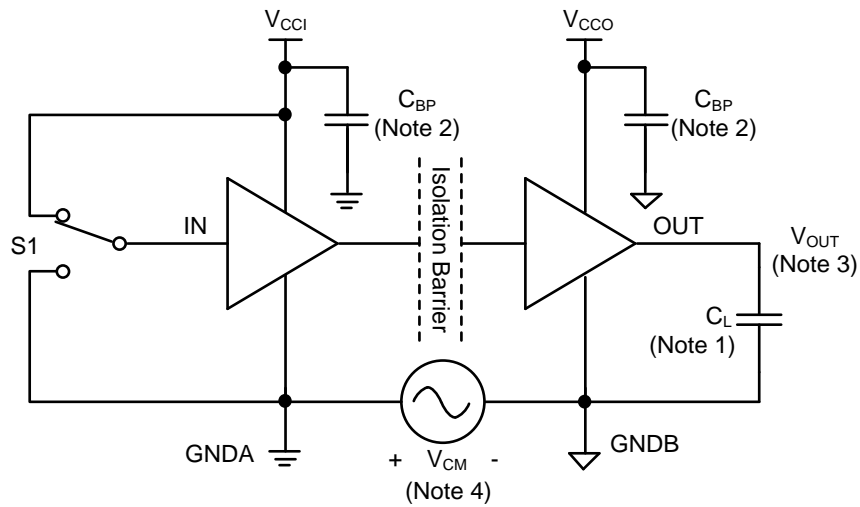
8 Parameter Measurement Information (continued)

Note 1: $C_L = 15\text{pF}$ and includes external circuit (instrumentation and fixture etc.) capacitance.

Note 2: C_{BP} (0.1 ~ 1 μF) is bypass capacitance.

Note 3: Pass-fail criteria: the output must remain stable.

Note 4: The High Voltage Surge Generator generates repetitive high voltage surges with >1kV amplitude, rise time <10ns and fall time <10ns, to reach common-mode transient noise with >150kV/ μs slew rate.

Figure 8-3. Common-Mode Transient Immunity Test Circuit

9 Detailed Description

9.1 Overview

The UMISO772x devices are a family of automotive, 2-channel digital galvanic isolators using Union’s full differential capacitive isolation technology. These devices have an ON-OFF keying (OOK) modulation scheme to transfer digital signals across the SiO₂ based isolation barrier between circuits with different power domains. The transmitter sends a high frequency carrier across the barrier to represent one digital state and sends no signal to represent the other digital state. The receiver demodulates the signal and recovers input signal at output through a buffer stage. With this OOK architecture, UMISO772x devices build a robust data transmission path between different power domains, without any special start-up initialization requirement.

These devices also incorporate advanced full differential techniques to maximize the CMTI performance and minimize the radiated emissions due the high frequency carrier and I/O buffer switching.

9.2 Functional Block Diagram

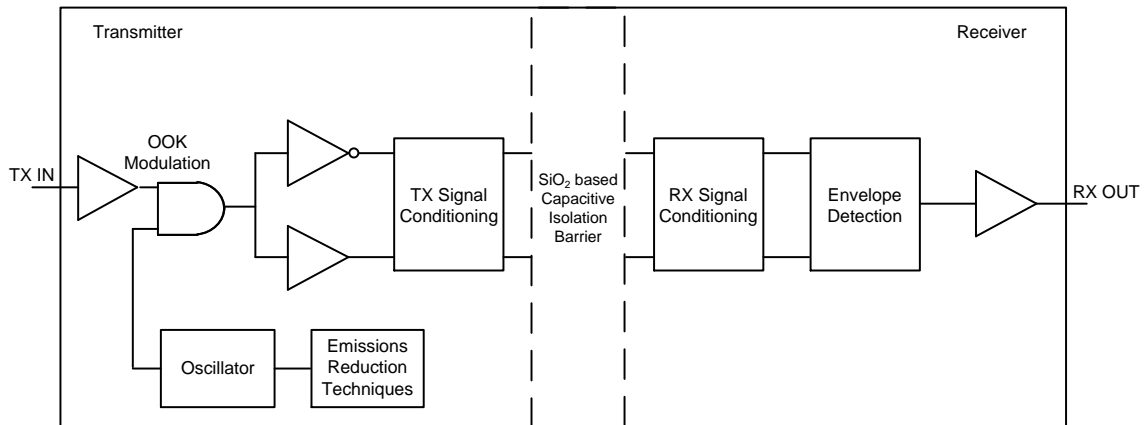

Figure 9-1. Functional Block Diagram of a Single Channel

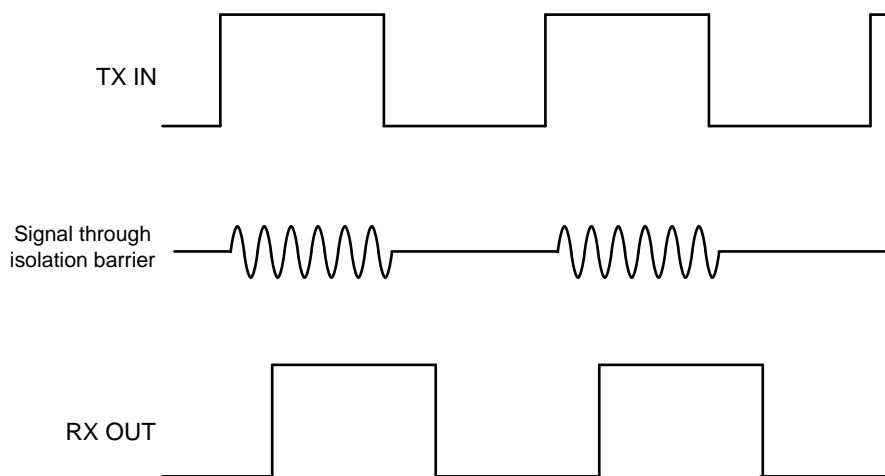

Figure 9-2. Conceptual Operation Waveforms of a Single Channel

9.3 Device Operation Modes (Note 1, 2, 3)

Table 9-1 lists the operation modes for the UMISO772x devices.

Table 9-1. Operation Mode Table (Note 1, 2)

V _{CCI}	V _{CCO}	Input (IN _x)	Output (OUT _x)	Operation
X	PD	X	Undetermined	If the output side V _{CCO} is unpowered, a channel output is undetermined. (Note 3)
X	PU	X	Z	High impedance mode: A low level of Enable pin causes the output to be high impedance.
PD	PU	X	Default	Default output mode: When V _{CCI} is unpowered, a channel output assumes the logic state based on its default option. Default is High for UMISO772xH and Low for UMISO772xL .
PU	PU	H	H	Normal operation mode: A channel output follows the logic state of its input.
		L	L	
		Open	Default	Default output mode: When input is open, the corresponding channel output goes to its default logic state. Default is High for UMISO772xH and Low for UMISO772xL .

Note 1: V_{CCI} = Input-side V_{CC}; V_{CCO} = Output-side V_{CC}; PU = Powered up (V_{CC} ≥ V_{CC(UVLO+)}); PD = Powered down (V_{CC} ≤ V_{CC(UVLO-)}); X = Irrelevant; H = High level; L = Low level; Z = High Impedance.

Note 2: A strongly driven input signal can weakly power the floating V_{CC} through an internal protection diode and cause undetermined output.

Note 3: The outputs are in undetermined state when V_{CC(UVLO+)} < V_{CCI}, V_{CCO} < V_{CC(UVLO-)}.

10 Application and Implementation

10.1 Application Information

The UMISO772x isolation ICs provide complete galvanic isolation between two power domains, protecting circuits from high common-mode transients and faults, and eliminating ground loops. In many applications, digital isolators are replacing optocouplers because they can reduce the power requirements and take up less board space while offering the same isolation capability. The UMISO772x devices are the high-performance, 2-channel digital isolators. Unlike optocouplers, which require external components to improve performance, provide bias, or limit current, the UMISO772x devices only require two external bypass capacitors to operate. To reduce ripple and the chance of introducing data errors, bypass V_{CCA} and V_{CCB} pins with $0.1\mu\text{F}$ to $1\mu\text{F}$ low-ESR ceramic capacitors to GNDA and GNDB respectively. Place the bypass capacitors as close to the power supply input pins as possible.

10.2 Typical Application

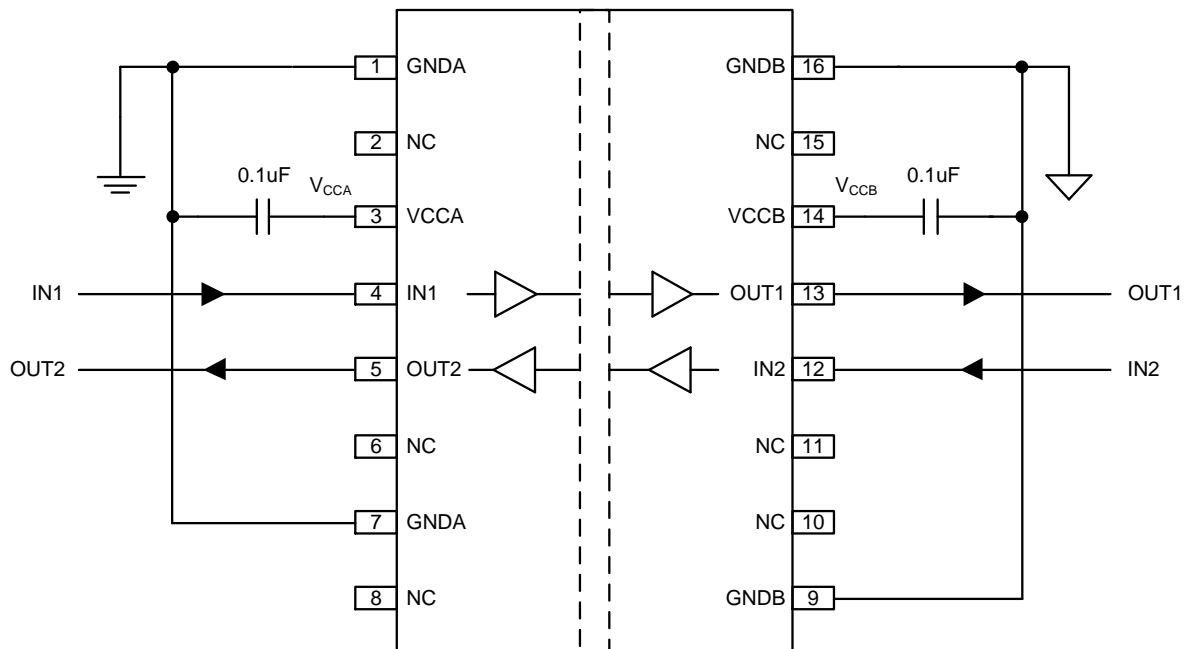
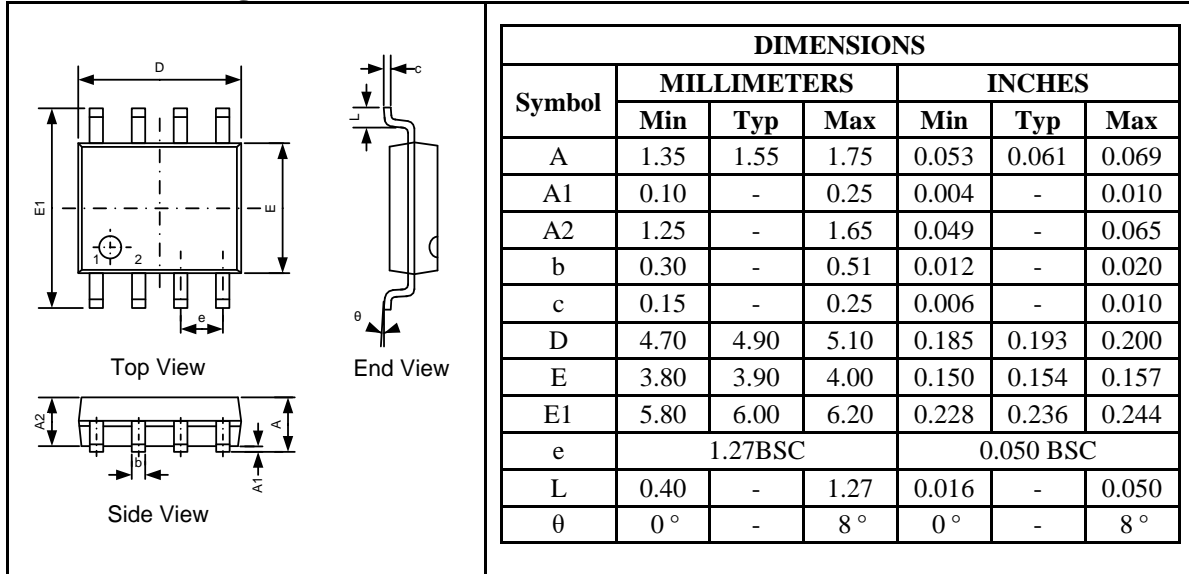

Figure 10-1. UMISO7721 Typical Application

Package Information

SOP8

Outline Drawing



Land Pattern

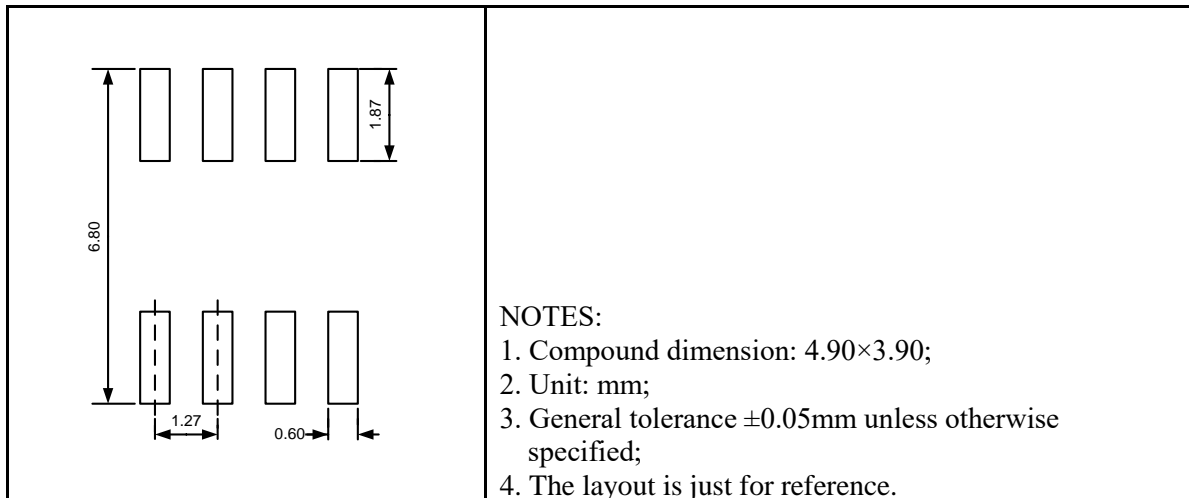

WSOP8

Outline Drawing

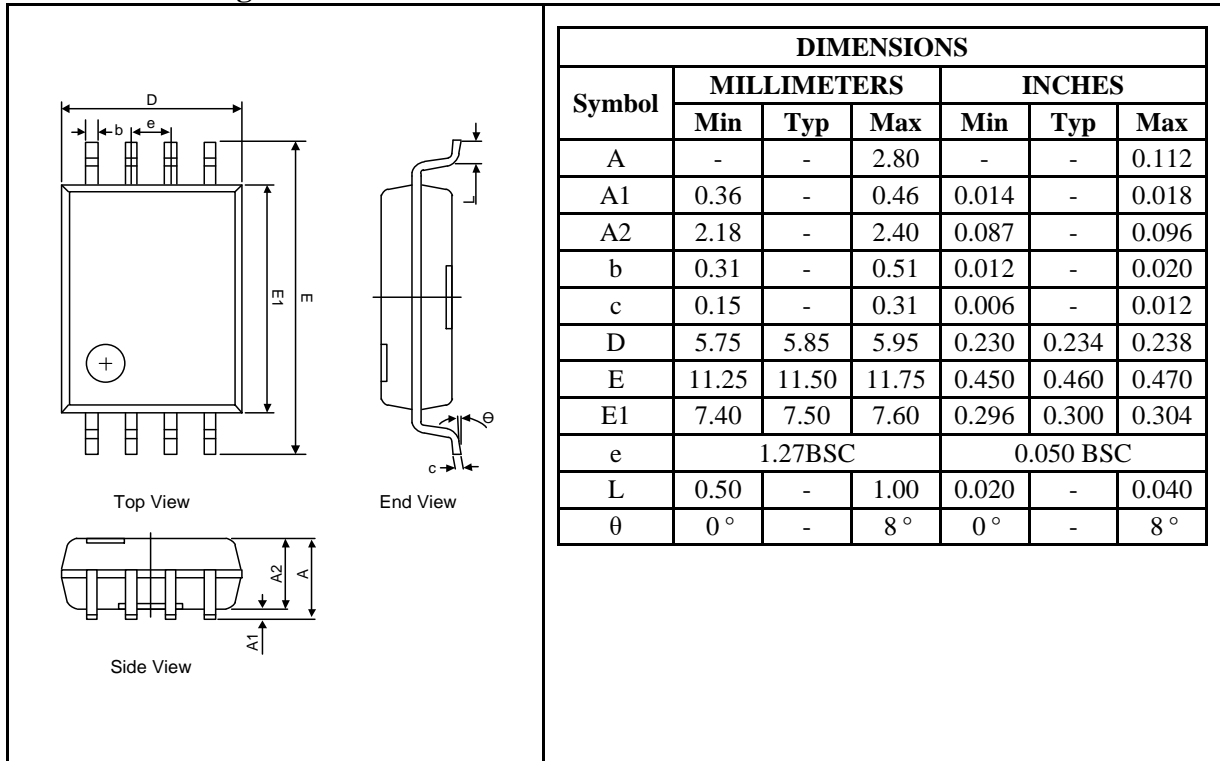

Land Pattern

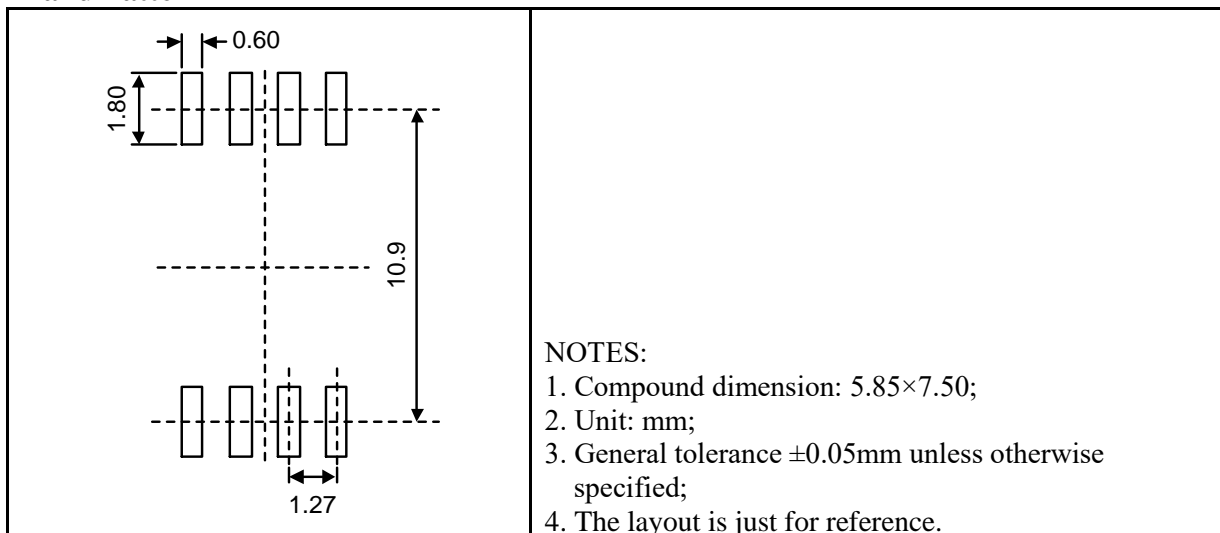

WSOP16

Outline Drawing

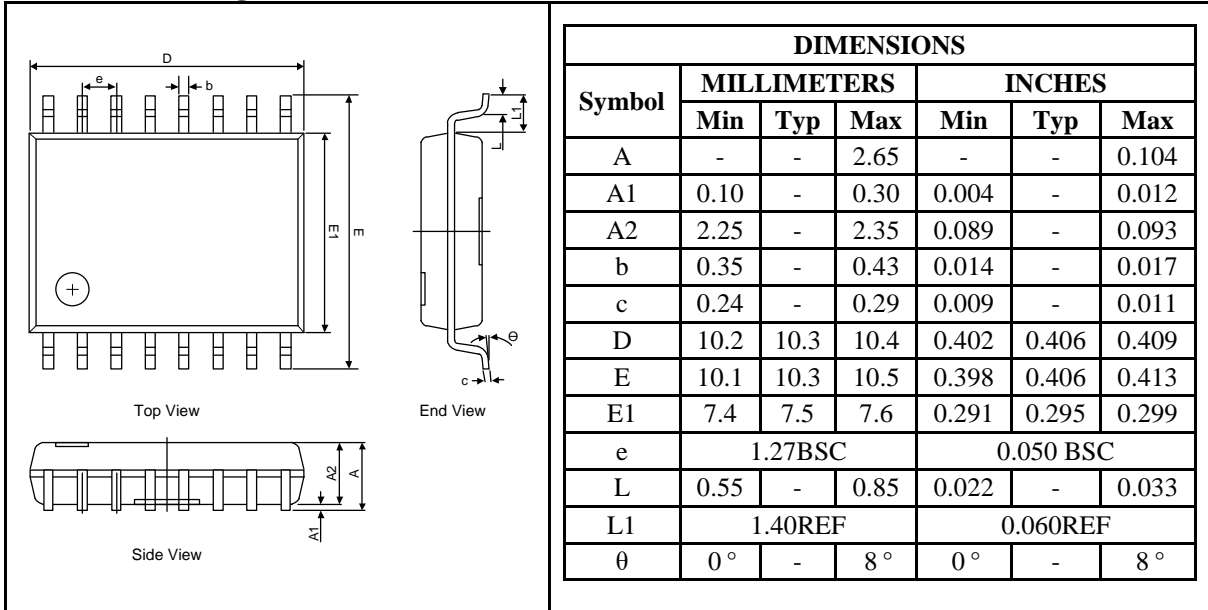

Land Pattern

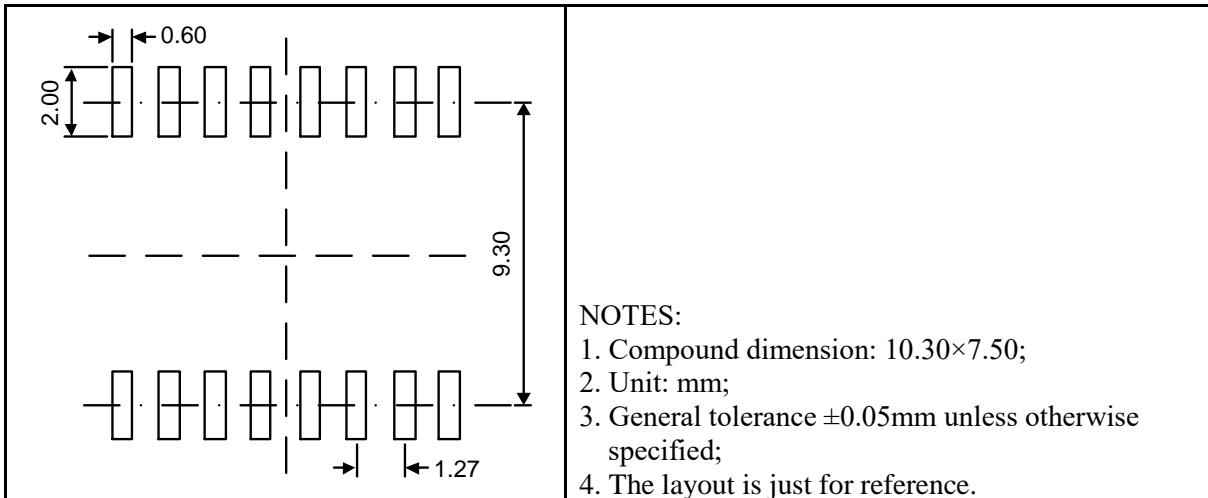

Packing Information

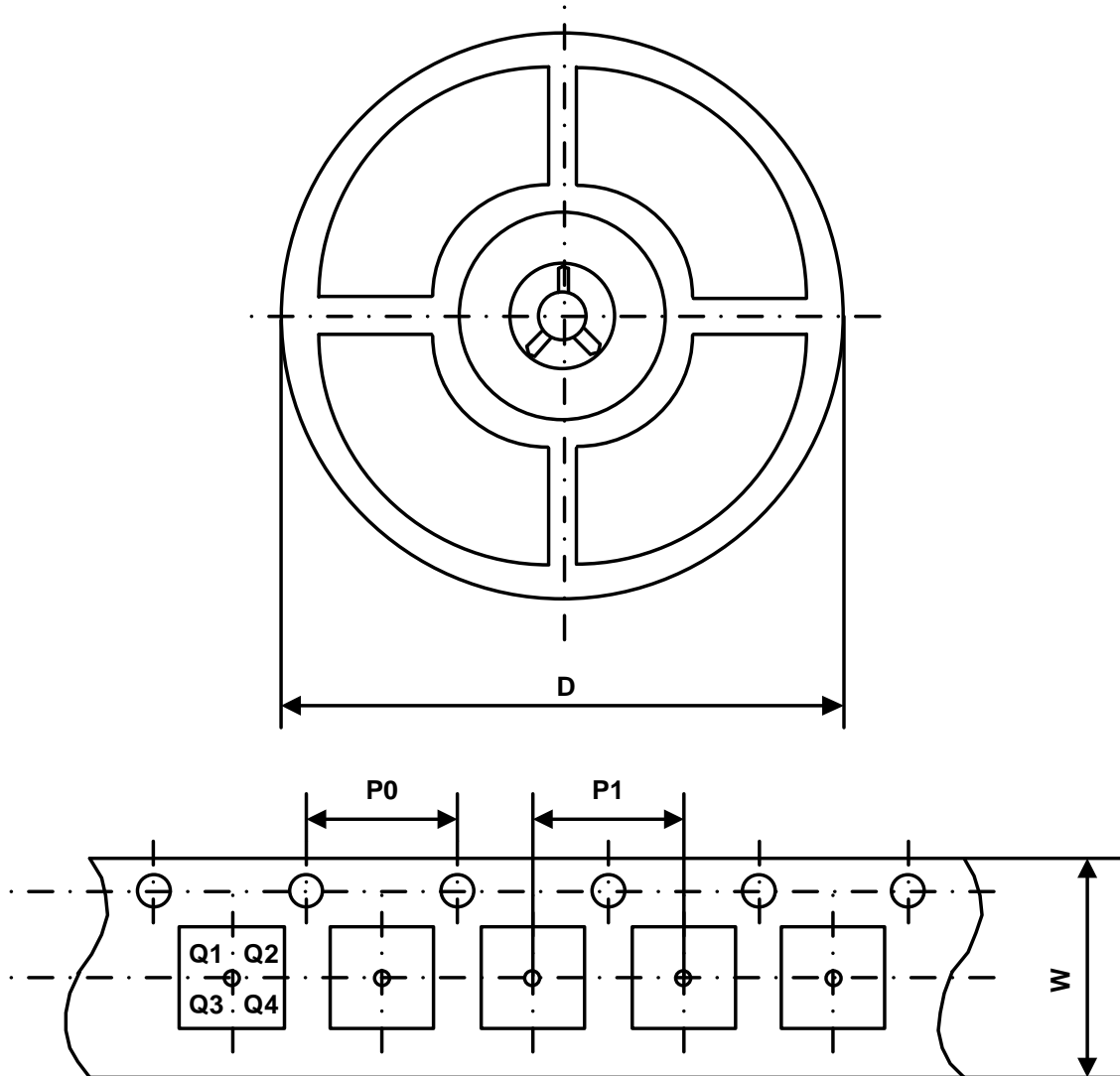

Part Number	Package Type	Carrier Width (W)	Pitch (P0)	Pitch (P1)	Reel Size (D)	PIN 1 Quadrant
UMISO7720LS8	SOP8	12 mm	4 mm	8 mm	330 mm	Q1
UMISO7720HS8	SOP8	12 mm	4 mm	8 mm	330 mm	Q1
UMISO7721LS8	SOP8	12 mm	4 mm	8 mm	330 mm	Q1
UMISO7721HS8	SOP8	12 mm	4 mm	8 mm	330 mm	Q1
UMISO7723LS8	SOP8	12 mm	4 mm	8 mm	330 mm	Q1
UMISO7723HS8	SOP8	12 mm	4 mm	8 mm	330 mm	Q1

Part Number	Package Type	Carrier Width (W)	Pitch (P0)	Pitch (P1)	Reel Size (D)	PIN 1 Quadrant
UMISO7720LWS8	WSOP8	16 mm	4 mm	16 mm	330 mm	Q1
UMISO7720HWS8	WSOP8	16 mm	4 mm	16 mm	330 mm	Q1
UMISO7721LWS8	WSOP8	16 mm	4 mm	16 mm	330 mm	Q1
UMISO7721HWS8	WSOP8	16 mm	4 mm	16 mm	330 mm	Q1
UMISO7723LWS8	WSOP8	16 mm	4 mm	16 mm	330 mm	Q1
UMISO7723HWS8	WSOP8	16 mm	4 mm	16 mm	330 mm	Q1
UMISO7720LWSG	WSOP16	16 mm	4 mm	12 mm	330 mm	Q1
UMISO7720HWSG	WSOP16	16 mm	4 mm	12 mm	330 mm	Q1
UMISO7721LWSG	WSOP16	16 mm	4 mm	12 mm	330 mm	Q1
UMISO7721HWSG	WSOP16	16 mm	4 mm	12 mm	330 mm	Q1
UMISO7723LWSG	WSOP16	16 mm	4 mm	12 mm	330 mm	Q1
UMISO7723HWSG	WSOP16	16 mm	4 mm	12 mm	330 mm	Q1

GREEN COMPLIANCE

Union Semiconductor is committed to environmental excellence in all aspects of its operations including meeting or exceeding regulatory requirements with respect to the use of hazardous substances. Numerous successful programs have been implemented to reduce the use of hazardous substances and/or emissions.

All Union components are compliant with the RoHS directive, which helps to support customers in their compliance with environmental directives. For more green compliance information, please visit:

<https://www.union-ic.com/Quality.html>

IMPORTANT NOTICE

The information in this document has been carefully reviewed and is believed to be accurate. Nonetheless, this document is subject to change without notice. Union assumes no responsibility for any inaccuracies that may be contained in this document, and makes no commitment to update or to keep current the contained information, or to notify a person or organization of any update. Union reserves the right to make changes, at any time, in order to improve reliability, function or design and to attempt to supply the best product possible.