

具备自动方向控制功能的3V至5.5V RS-485收发器

UM3481D SOP8/MSOP8/DFN8 3.0×3.0
UM13082D SOP8/MSOP8/DFN8 3.0×3.0

1 描述

UM3481D与UM13082D是面向工业应用的高可靠性半双工RS-485收发器。这些器件采用数据输入引脚实现自动方向控制，减少了对独立使能引脚的依赖，从而无需单独设置驱动器使能和接收器使能功能。

这些器件支持两种速度等级。UM3481D支持1Mbps传输速率，UM13082D支持10Mbps传输速率。所有器件均采用3V至5.5V单电源供电。其具备扩展级的±15V共模电压范围与总线引脚低输入漏电流特性，可满足长电缆线的多点传输应用需求。

UM3481D和UM13082D提供SOP8、MSOP8及DFN8 3.0×3.0封装，专为空间受限型应用设计。这些器件工作环境温度范围为-40°C至125°C。

2 特性

- 符合或超出TIA/EIA-485A标准的要求
- 电源电压范围：3V至5.5V
- 数据输入引脚实现自动方向控制
- 总线I/O保护
 - ±18V直流总线故障保护
 - ±8kV人体放电模型
 - ±9kV IEC 61000-4-2接触放电
- 闩锁(Latch-up)性能超过200mA，符合JESD 78规范
- 扩展级运行共模范围：±15V
- 适用于热插拔功能的无干扰上电/断电
- 超2.1V差分输出电压，可在5V供电条件下满足PROFIBUS兼容
- 具有两种速度等级：
 - 1Mbps (UM3481D)
 - 10Mbps (UM13082D)
- 工作环境温度范围：-40°C to 125°C
- 增强型接收器迟滞，具备高抗噪能力
- 低功耗：
 - 运行期间静态电流：
1.7 mA (典型值)
- 开路、短路和空闲总线失效防护
- 1/8单位负载(多达256个总线节点)
- 热关断

3 应用

- 工厂自动化与控制
- HVAC系统
- 智能电表
- 楼宇自动化
- 视频监控系统

4 Selection Guide

Part Number	Data Rate (Mbps)	V _{CC} Range (V)	Bus Fault Protection (V)
UM3481D	1	3.0 to 5.5	-18 to +18
UM13082D	10	3.0 to 5.5	-18 to +18

5 Ordering Information

Part Number	Mark Code	Package Type	Shipping Qty
UM3481DEESA	UM3481DEESA	SOP8	3000pcs/13Inch Tape & Reel
UM3481DEEM8	3481D	MSOP8	4000pcs/13Inch Tape & Reel
UM3481DEEDA	3481D	DFN8 3.0×3.0	3000pcs/13Inch Tape & Reel
UM13082DEESA	UM13082DEESA	SOP8	3000pcs/13Inch Tape & Reel
UM13082DEEM8	13082D	MSOP8	4000pcs/13Inch Tape & Reel
UM13082DEEDA	13082D	DFN8 3.0×3.0	3000pcs/13Inch Tape & Reel

6 Pin Configuration and Function

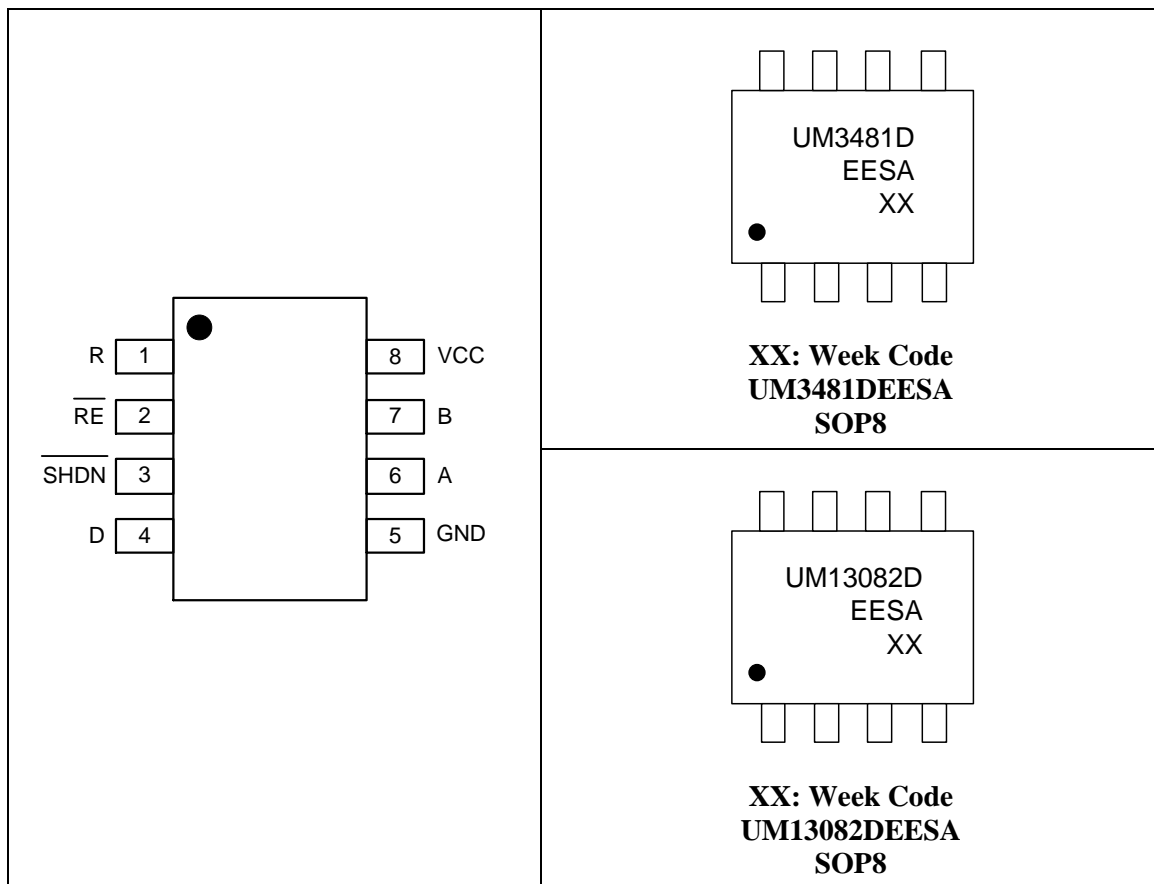

6 Pin Configuration and Function (continued)

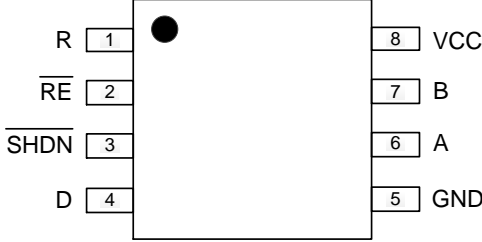
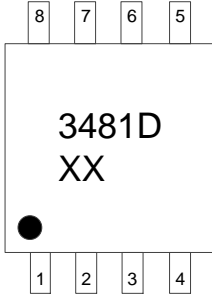
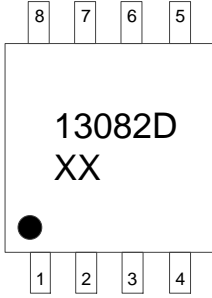
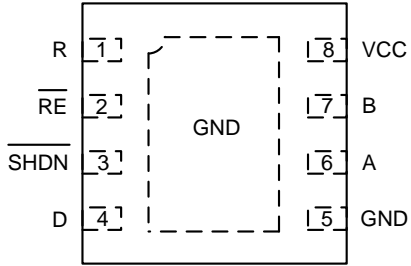
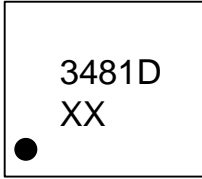
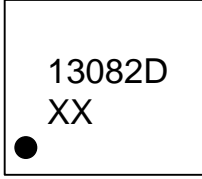
	 <p>XX: Week Code UM3481DEEM8 MSOP8</p>
	 <p>XX: Week Code UM13082DEEM8 MSOP8</p>
	 <p>XX: Week Code UM3481DEEDA DFN8 3.0×3.0</p>
	 <p>XX: Week Code UM13082DEEDA DFN8 3.0×3.0</p>

6 Pin Configuration and Function (continued)

Table 6-1. Pin Functions

Pin No.	Pin Name	Function
1	R	Receive data output
2	$\overline{\text{RE}}$	Receiver enable, active low; integrated pull-up
3	$\overline{\text{SHDN}}$	Shutdown enable, active low; integrated pull-up
4	D	Driver data input; integrated pull-up
5	GND	Local device ground
6	A	Driver output or receiver input (complementary to B)
7	B	Driver output or receiver input (complementary to A)
8	VCC	Supply voltage

7 Specifications

7.1 Absolute Maximum Ratings (Note 1)

Symbol	Parameter	Conditions	Min	Typ	Max	Unit
V _{CC}	Supply voltage		-0.5		6.5	V
V _I	Voltage on A, B		-18		18	V
	Voltage on any logic pin (D, SHDN , RE)		-0.3		6.5	V
V _{ESD}	Human body model (HBM), per ANSI/ESDA/JEDEC JS-001	All pins		±8		kV
	Contact discharge, per IEC 61000-4-2	Bus terminals and GND		±9		kV
I _O	RXD output current		-24		24	mA
T _{STG}	Storage temperature		-65		150	°C
T _L	Lead Temperature for Soldering 10 Seconds				260	°C

Note 1: Operation outside the Absolute Maximum Ratings may cause permanent device damage. Absolute maximum ratings do not imply functional operation of the device at these or any other conditions beyond those listed under Recommended Operating Conditions. If briefly operating outside the Recommended Operating Conditions but within the Absolute Maximum Ratings, the device may not sustain damage, but it may not be fully functional. Operating the device in this manner may affect device reliability, functionality, performance, and shorten the device lifetime.

7.2 Recommended Operating Conditions

Symbol	Parameter	Conditions	Min	Typ	Max	Unit
V _{CC}	Supply Voltage		3		5.5	V
V _I	Input voltage at any bus terminal (separately or common mode)	Note 1	-15		15	V
V _{ID}	Differential input voltage		-15		15	V
I _O	Output current, driver		-60		60	mA
I _{OR}	Output current, receiver		-8		8	mA
R _L	Differential load resistance		54	60		Ω
1/ t _{UI}	Signaling rate (UM3481D)				1	Mbps
	Signaling rate (UM13082D)				10	Mbps
T _A	Operating free-air temperature (see application section for thermal information)		-40		125	°C
T _J	Junction temperature		-40		150	°C

Note 1: The algebraic convention, in which the least positive (most negative) limit is designated as minimum is used in this data sheet.

7.3 Electrical Characteristics (Static)

over operating free-air temperature range (unless otherwise noted). All typical values are at 25°C and supply voltage of $V_{CC} = 5\text{ V}$.

Symbol	Parameter	Conditions	Min	Typ	Max	Unit
Supply						
I_{CC}	Supply current, $V_{CC} = 3.6\text{ V}$	$\overline{\text{SHDN}} = V_{CC}$, $\overline{\text{RE}} = 0$, $D = 0$, No load (Driver and receiver enabled)		1.6	3	mA
		$\overline{\text{SHDN}} = V_{CC}$, $\overline{\text{RE}} = V_{CC}$, $D = 0$, No load (Driver enabled, receiver disabled)		1.6	3	mA
		$\overline{\text{SHDN}} = 0\text{ V}$, No load (Driver and receiver disabled)		3.3	15	μA
I_{CC}	Supply current, $V_{CC} = 5.5\text{ V}$	$\overline{\text{SHDN}} = V_{CC}$, $\overline{\text{RE}} = 0$, $D = 0$, No load (Driver and receiver enabled)		1.7	3	mA
		$\overline{\text{SHDN}} = V_{CC}$, $\overline{\text{RE}} = V_{CC}$, $D = 0$, No load (Driver enabled, receiver disabled)		1.7	3	mA
		$\overline{\text{SHDN}} = 0\text{ V}$, No load (Driver and receiver disabled)		5	15	μA
Driver						
$ V_{OD} $	Driver differential output voltage magnitude	$R_L = 60\ \Omega$, $-15\text{ V} \leq V_{\text{TEST}} \leq 15\text{ V}$, See Figure 8-1	1.5	3.4		V
		$R_L = 60\ \Omega$, $-15\text{ V} \leq V_{\text{TEST}} \leq 15\text{ V}$, $4.5\text{ V} \leq V_{CC} \leq 5.5\text{ V}$, See Figure 8-1	2.1	3.4		V
		$R_L = 100\ \Omega$, See Figure 8-2	2	4		V
		$R_L = 54\ \Omega$, See Figure 8-2	1.5	3.4		V
		$R_L = 54\ \Omega$, $4.5\text{ V} \leq V_{CC} \leq 5.5\text{ V}$, See Figure 8-2	2.1	3.4		V

7.3 Electrical Characteristics (Static) (continued)

over operating free-air temperature range (unless otherwise noted). All typical values are at 25°C and supply voltage of $V_{CC} = 5\text{ V}$.

Symbol	Parameter	Conditions	Min	Typ	Max	Unit
$\Delta V_{OD} $	Change in magnitude of driver differential output voltage	$R_L = 54\ \Omega$ or $100\ \Omega$ See Figure 8-2	-50		50	mV
V_{OC}	Common-mode output voltage	$R_L = 54\ \Omega$ or $100\ \Omega$ See Figure 8-2	1	$V_{CC}/2$	3	V
$\Delta V_{OC(SS)}$	Change in differential driver common-mode output voltage	$R_L = 54\ \Omega$ or $100\ \Omega$ See Figure 8-2	-50		50	mV
$V_{OC(PP)}$	Peak-to-peak driver common-mode output voltage	$R_L = 54\ \Omega$ or $100\ \Omega$, $V_{CC} = 3.3\text{ V}$, See Figure 8-2		200		mV
I_{OS}	Short-circuit output current	$-15\text{ V} \leq (V_A \text{ or } V_B) \leq 15\text{ V}$, or A pin shorted to B pin	-250		250	mA
Receiver						
I_I	Bus input current	$V_{CC} = 0\text{ V}$ or 5.5 V , $V_I = 12\text{ V}$		70	125	μA
		$V_{CC} = 0\text{ V}$ or 5.5 V , $V_I = -7\text{ V}$	-100	-60		
V_{TH+}	Positive-going input threshold voltage	Over common-mode range of $\pm 15\text{ V}$	40	125	200	mV
V_{TH-}	Negative-going input threshold voltage		-200	-125	-40	
V_{HYS}	Input hysteresis			250		
$C_{A,B}$	Input differential capacitance	Measured between A and B, $f = 1\text{ MHz}$		50		pF
V_{OH}	Output high voltage	$I_{OH} = -8\text{ mA}$	$V_{CC} - 0.4$	$V_{CC} - 0.2$		V
V_{OL}	Output low voltage	$I_{OL} = 8\text{ mA}$		0.2	0.4	V
I_{OZ}	Output high-impedance current	$V_O = 0\text{ V}$ or V_{CC} , $\overline{RE} = V_{CC}$	-1		1	μA
Logic						
V_{IH}	Input High Voltage	D, \overline{RE} , \overline{SHDN}	$0.7V_{CC}$			V
V_{IL}	Input low Voltage	D, \overline{RE} , \overline{SHDN}			$0.3V_{CC}$	V

7.3 Electrical Characteristics (Static) (continued)

over operating free-air temperature range (unless otherwise noted). All typical values are at 25°C and supply voltage of $V_{CC}=5\text{ V}$.

Symbol	Parameter	Conditions	Min	Typ	Max	Unit
I_I	Input current on D, \overline{RE} , \overline{SHDN} pin	$3\text{ V} \leq V_{CC} \leq 5.5\text{ V}$, $0\text{ V} \leq V_{IN} \leq V_{CC}\text{ V}$	-5		5	μA
Thermal Protection						
T_{SD}	Thermal shutdown threshold	Temperature rising	150	170		$^{\circ}\text{C}$
T_{HYS}	Thermal shutdown hysteresis			10		$^{\circ}\text{C}$

7.4 Electrical Characteristics (Dynamic)_1Mbps

over recommended operating conditions. All typical values are at 25°C and supply voltage of $V_{CC}=5V$.

Symbol	Parameter	Conditions	Min	Typ	Max	Unit
Driver						
t_R, t_F	Driver differential output rise/fall time	$R_L = 54 \Omega, C_L = 50 \text{ pF}$, see Figure 8-3	130	475	700	ns
t_{PHL}, t_{PLH}	Driver propagation delay time			300	350	ns
$t_{SK(P)}$	Driver differential output pulse skew, $ t_{PHL} - t_{PLH} $			3.5	10	ns
t_{PHZ}, t_{PLZ}	Disable time	See Figure 8-4 and Figure 8-5		980	1200	ns
t_{PZH}, t_{PZL}	Enable time	see Figure 8-4 and Figure 8-5		2.5	4.6	μs
$t_{DEVICE(AUTO-DIR)}$	Driver active time in the auto-direction mode when $\overline{\text{SHDN}}$ is high and D switches from low to high	Driver active time in the auto-direction mode when $\overline{\text{SHDN}}$ is high and D turns from low to high, see Figure 8-8	4	10	14	μs
Receiver						
t_R, t_F	Receiver output rise/fall time	$C_L = 15 \text{ pF}$, see Figure 8-6		9	20	ns
t_{PHL}, t_{PLH}	Receiver propagation delay time			53	80	ns
$t_{SK(P)}$	Receiver output pulse skew, $ t_{PHL} - t_{PLH} $			1	12.5	ns
t_{PHZ}, t_{PLZ}	Receiver disable time			30	50	ns
t_{PZL}, t_{PZH}	Receiver enable time	Driver enabled, see Figure 8-7		30	120	ns

7.4 Electrical Characteristics (Dynamic)_10Mbps

over recommended operating conditions. All typical values are at 25°C and supply voltage of $V_{CC}=5V$.

Symbol	Parameter	Conditions	Min	Typ	Max	Unit
Driver						
t_R, t_F	Driver differential output rise/fall time	$R_L = 54 \Omega, C_L = 50 \text{ pF}$, see Figure 8-3	3.5	13	15	ns
t_{PHL}, t_{PLH}	Driver propagation delay time		4	15	25	ns
$t_{SK(P)}$	Driver differential output pulse skew, $ t_{PHL} - t_{PLH} $			0.5	3	ns
t_{PHZ}, t_{PLZ}	Disable time	See Figure 8-4 and Figure 8-5		830	1200	ns
t_{PZH}, t_{PZL}	Enable time	see Figure 8-4 and Figure 8-5		2.4	4.5	μs
$t_{DEVICE(AUTO-DIR)}$	Driver active time in the auto-direction mode when $\overline{\text{SHDN}}$ is high and D switches from low to high	Driver active time in the auto-direction mode when $\overline{\text{SHDN}}$ is high and D turns from low to high, see Figure 8-8	0.4	2.9	4	μs
Receiver						
t_R, t_F	Receiver output rise/fall time	$C_L = 15 \text{ pF}$, see Figure 8-6		4	6	ns
t_{PHL}, t_{PLH}	Receiver propagation delay time		10	18	35	ns
$t_{SK(P)}$	Receiver output pulse skew, $ t_{PHL} - t_{PLH} $			0.5	5	ns
t_{PHZ}, t_{PLZ}	Receiver disable time	see Figure 8-7		15	50	ns
t_{PZL}, t_{PZH}	Receiver enable time			15	82	ns

8 Parameter Measurement Information

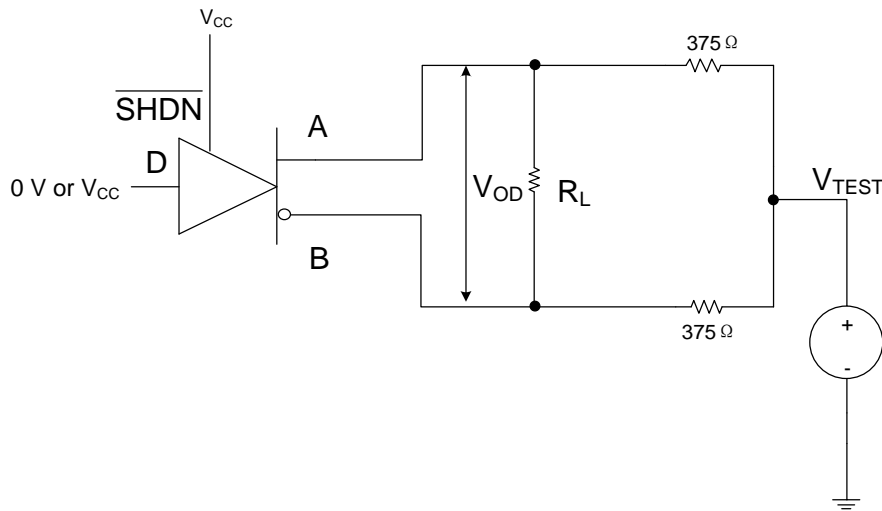

Figure 8-1. Measurement of Driver Differential Output Voltage With Common-Mode Load

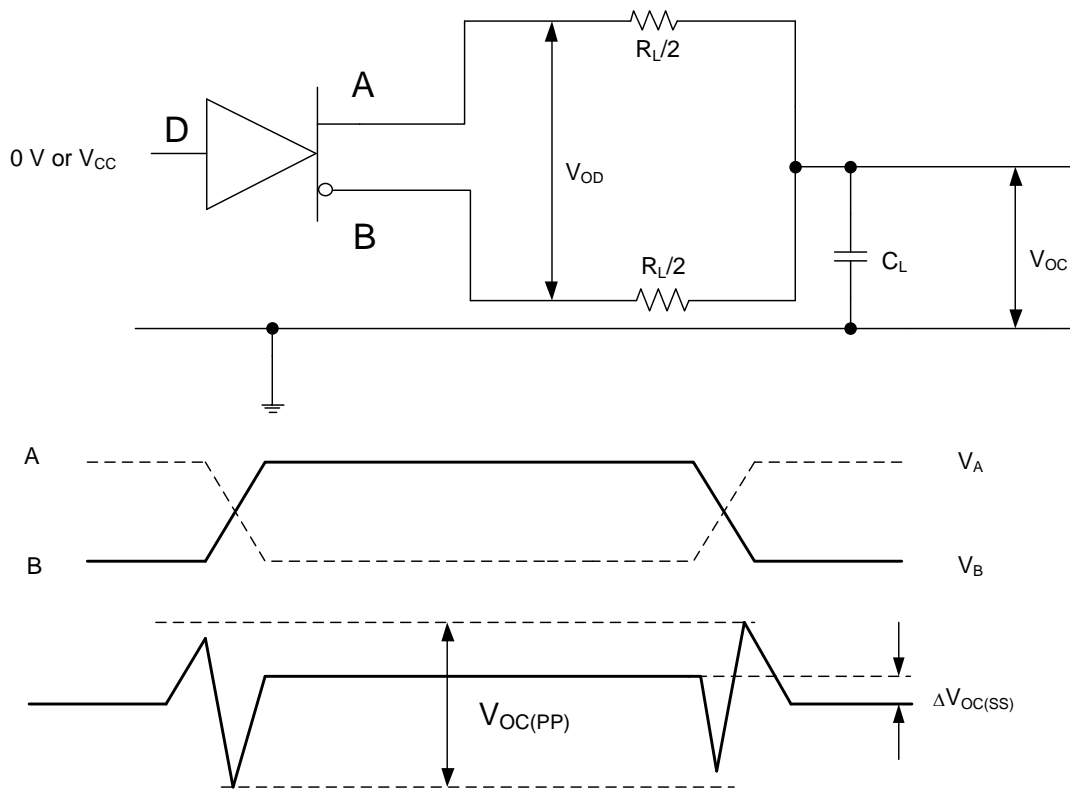

Figure 8-2. Measurement of Driver Differential and Common-Mode Output With RS-485 Load

8 Parameter Measurement Information (continued)

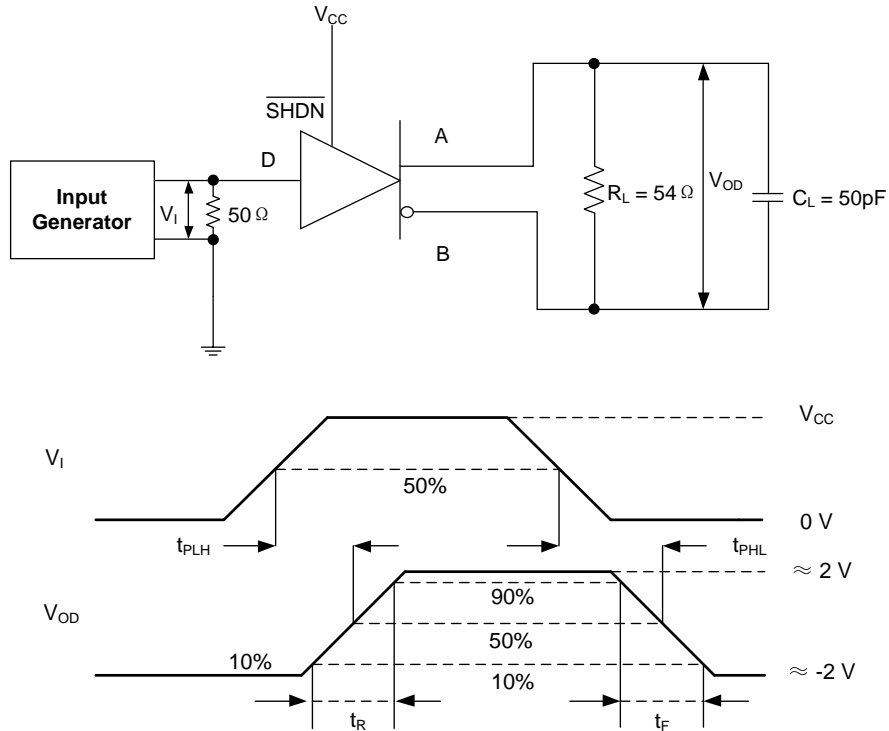

Figure 8-3. Measurement of Driver Differential Output Rise and Fall Times and Propagation Delays

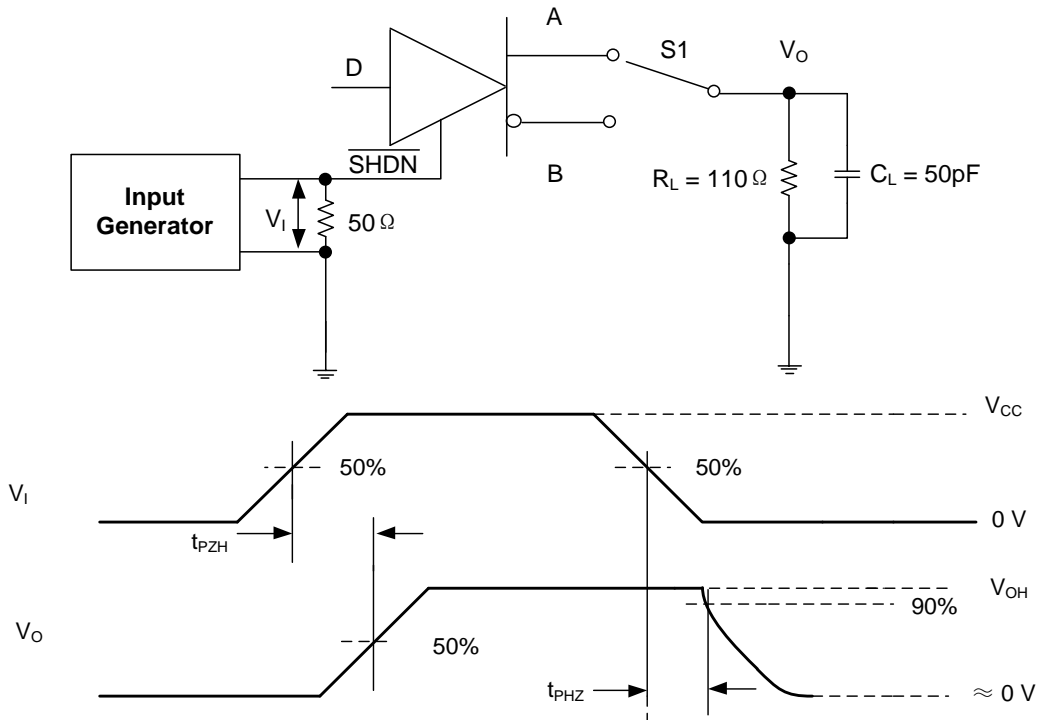

Figure 8-4. Measurement of Driver Enable and Disable Times With Active High Output and Pull-Down Load

8 Parameter Measurement Information (continued)

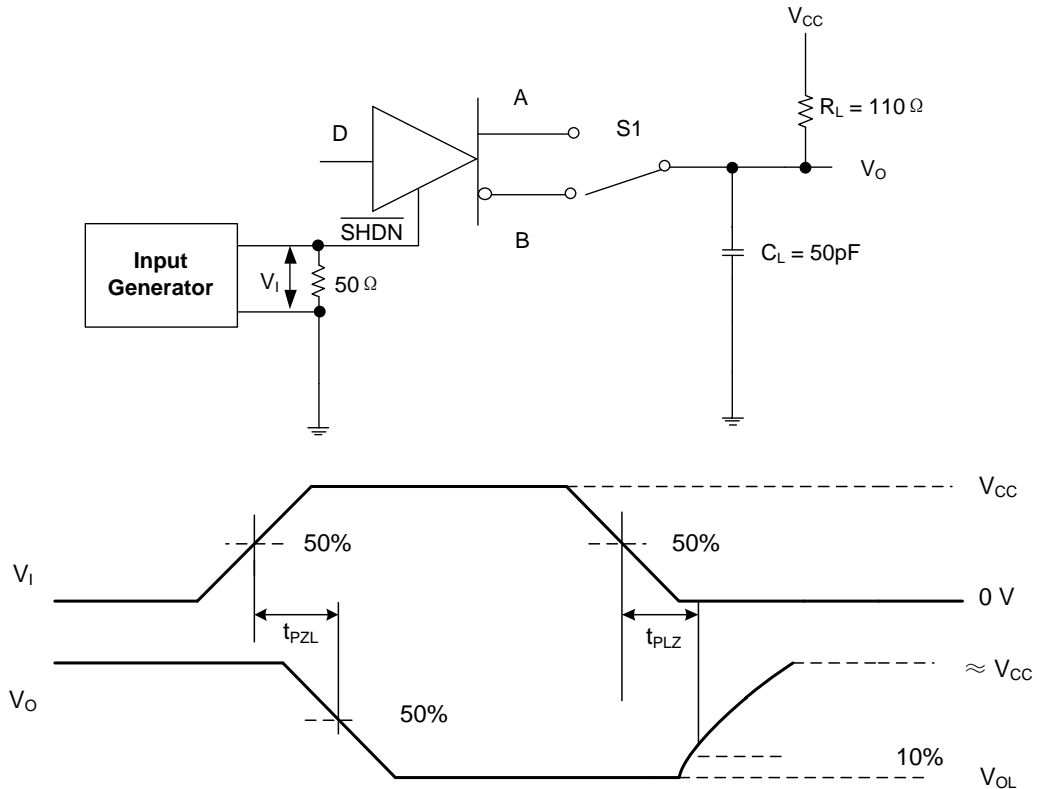

Figure 8-5. Measurement of Driver Enable and Disable Times With Active Low Output and Pull-up Load

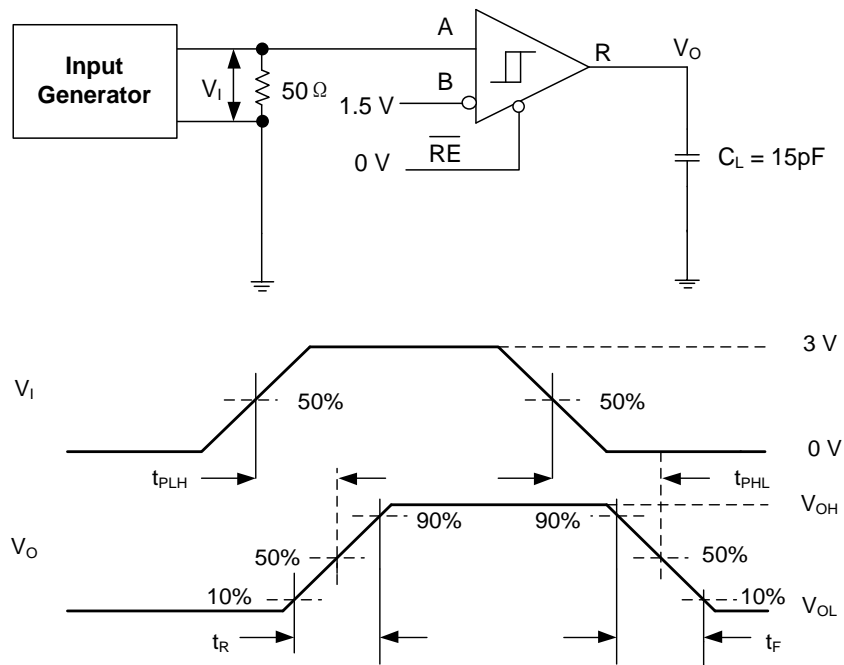

Figure 8-6. Measurement of Receiver Output Rise and Fall Times and Propagation Delays

8 Parameter Measurement Information (continued)

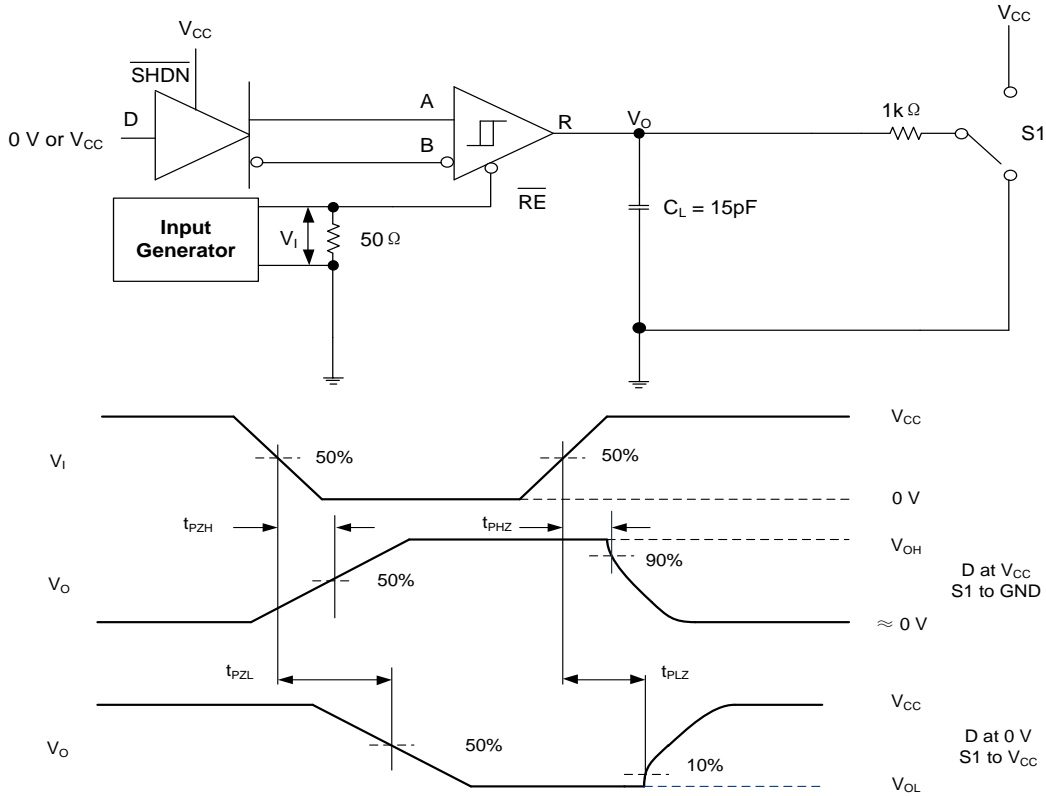

Figure 8-7. Measurement of Receiver Enable/Disable Times With Driver Enabled

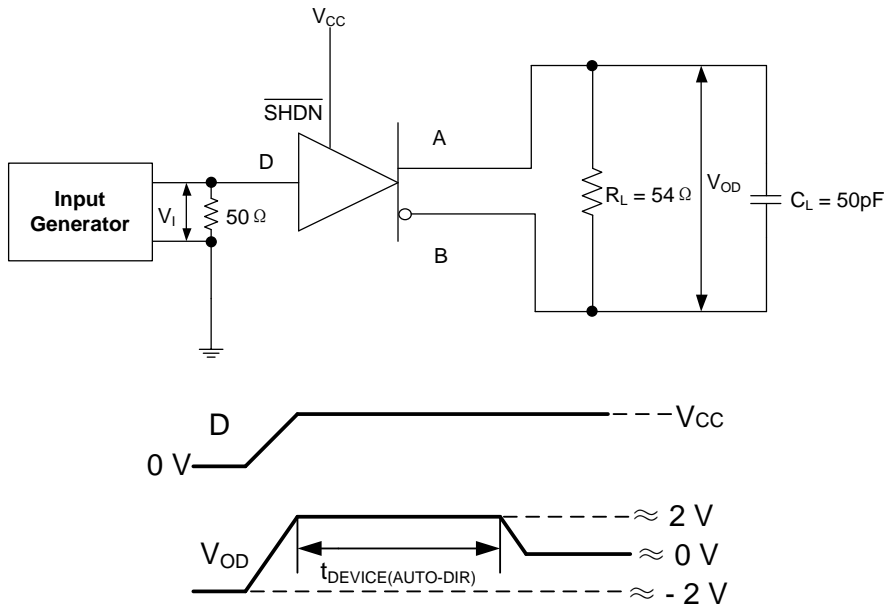

Figure 8-8. Measurement of Auto-direction Control Timing Parameter (t_{DEVICE(AUTO-DIR)})

9 Detailed Description

9.1 Overview

UM3481D and UM13082D feature auto-direction control using the data input pin that reduces the reliance on separate pins for driver-enable and the receiver-enable functionality. The UM3481D is available in speed grade suitable for data transmission up to 1 Mbps. The UM13082D is available in speed grade suitable for data transmission up to 10 Mbps.

9.2 Functional Block Diagram

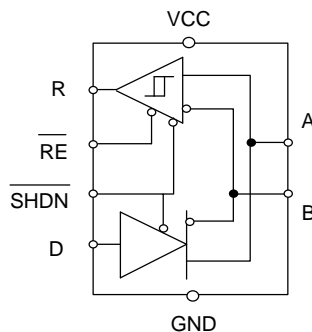

Figure 9-1. UM3481D and UM13082D Block Diagram

10 Feature Description

10.1 ±18-V Fault Protection

The devices have extended bus fault protection compared to standard RS-485 devices. Transceivers that operate in rugged industrial environments are often exposed to voltage transients greater than the -7 V to +12 V defined by the TIA/EIA-485A standard. To protect against such conditions, the generic RS-485 devices with lower absolute maximum ratings requires expensive external protection components. To simplify system design and reduce overall system cost, the devices are protected up to ±18 V without the need for any external components.

10.2 Device Functional Modes

When the shutdown pin, $\overline{\text{SHDN}}$, is logic high, the differential outputs A and B follow the logic states at data input D. When D is low, the output states reverse, B turns high, A becomes low, and V_{OD} is negative. A logic high at D causes A to turn high and B to turn low for a duration. In this case, the differential output voltage defined as $V_{OD} = V_A - V_B$ is positive for $t_{\text{DEVICE(AUTO-DIR)}}$. After this duration, the driver turns off and the receiver is enabled. The device can be used in auto-direction mode by tying $\overline{\text{SHDN}}$ and $\overline{\text{RE}}$ pins together to logic high and controlling the driver and receiver using the data input pin, D. This enables reducing the number of GPIO pins or the number of isolation channels required to operate the device. Please refer to Driver Function Table and Receiver Function Table for further details.

When $\overline{\text{SHDN}}$ is low, both the driver and the receiver are turned off and the device is in shutdown mode. In this condition, the logic state at D is irrelevant. The $\overline{\text{SHDN}}$ pin has an internal pull-up resistor to V_{CC} ; thus when left open, the driver is dependent on the status of the D pin. The D pin has an internal pull-up resistor to V_{CC} , thus, when left open while the driver is enabled for $t_{\text{DEVICE(AUTO-DIR)}}$, before being disabled.

10.2 Device Functional Modes (continued)

Table 10-1. Driver Function Table

Input	Enable	Output		Function
		A	B	
D	$\overline{\text{SHDN}}$	A	B	
X	L	Z	Z	Driver disabled. Device in shutdown mode.
H	H / Open	H	L	Actively drive bus high for $t_{\text{DEVICE(AUTO-DIR)}}$ and then bus is in high impedance.
L	H / Open	L	H	Actively drive bus low.
Open	H / Open	H	L	Actively drive bus high for $t_{\text{DEVICE(AUTO-DIR)}}$ and then bus is in high impedance.

When the receiver enable pin, $\overline{\text{RE}}$, is logic low, the receiver is enabled. When the differential input voltage defined as $V_{\text{ID}} = V_{\text{A}} - V_{\text{B}}$ is higher than the positive input threshold, $V_{\text{TH+}}$, the receiver output, R, turns high. When V_{ID} is lower than the negative input threshold, $V_{\text{TH-}}$, the receiver output, R, turns low. If V_{ID} is between $V_{\text{TH+}}$ and $V_{\text{TH-}}$, the output is indeterminate.

When $\overline{\text{RE}}$ is logic high or left open and D input is logic low, the receiver output is high-impedance and the magnitude and polarity of V_{ID} are irrelevant. Internal biasing of the receiver inputs causes the output to go failsafe-high when the transceiver is disconnected from the bus (open-circuit), or the bus lines are shorted to one another (short-circuit), or the bus is not actively driven (idle bus).

When $\overline{\text{RE}}$ is logic high or left open and D input switches from logic low to logic high, the receiver output is high-impedance for the duration of $t_{\text{DEVICE(AUTO-DIR)}}$. After the duration of $t_{\text{DEVICE(AUTO-DIR)}}$, the receiver turns ON and outputs a logic high or low depending upon the differential bus input voltage.

Table 10-2. Receiver Function Table

Differential Input	Enable	Input	Output	Function
$V_{\text{ID}} = V_{\text{A}} - V_{\text{B}}$	$\overline{\text{RE}}$	D	R	
X	H / Open	L	Z	Receiver disabled
X	H / Open	H	Z for $t_{\text{DEVICE(AUTO-DIR)}}$ followed by L or H depending upon bus input voltage	Receiver disabled by for $t_{\text{DEVICE(AUTO-DIR)}}$ after D switches from L to H. Receiver output follows bus input voltage after $t_{\text{DEVICE(AUTO-DIR)}}$
$V_{\text{TH+}} < V_{\text{ID}}$	L	X	H	Receive valid bus high
$V_{\text{TH-}} < V_{\text{ID}} < V_{\text{TH+}}$	L	X	N/A	Indeterminate bus state
$V_{\text{ID}} < V_{\text{TH-}}$	L	X	L	Receive valid bus low
Open-circuit bus	L	X	H	Fail-safe high output
Short-circuit bus	L	X	H	Fail-safe high output
Idle (terminated) bus	L	X	H	Fail-safe high output

Package Information

SOP8

Outline Drawing

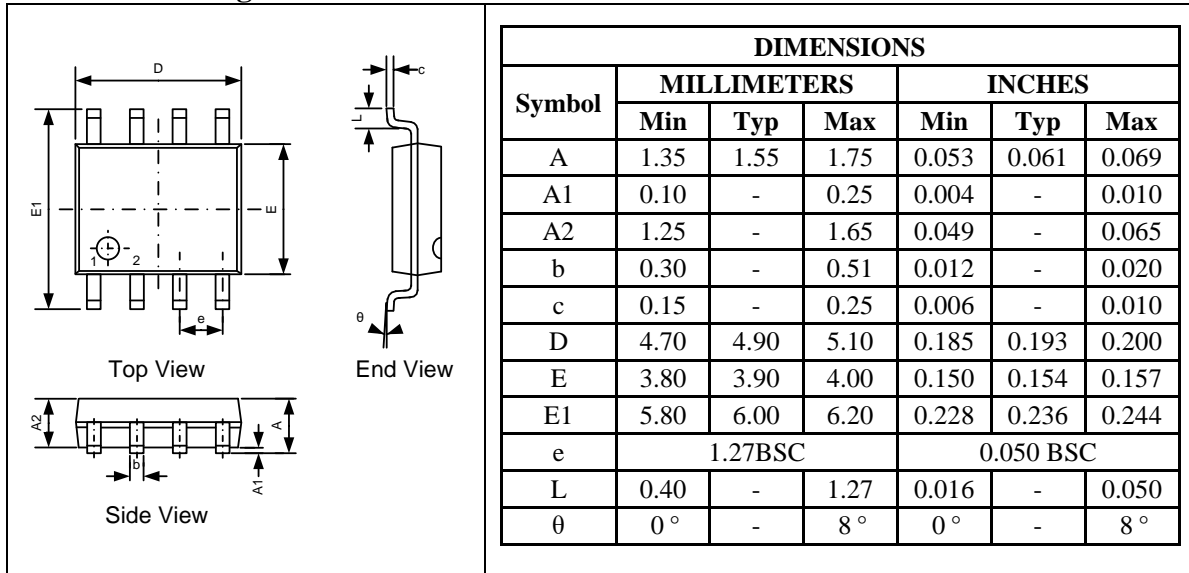

Land Pattern

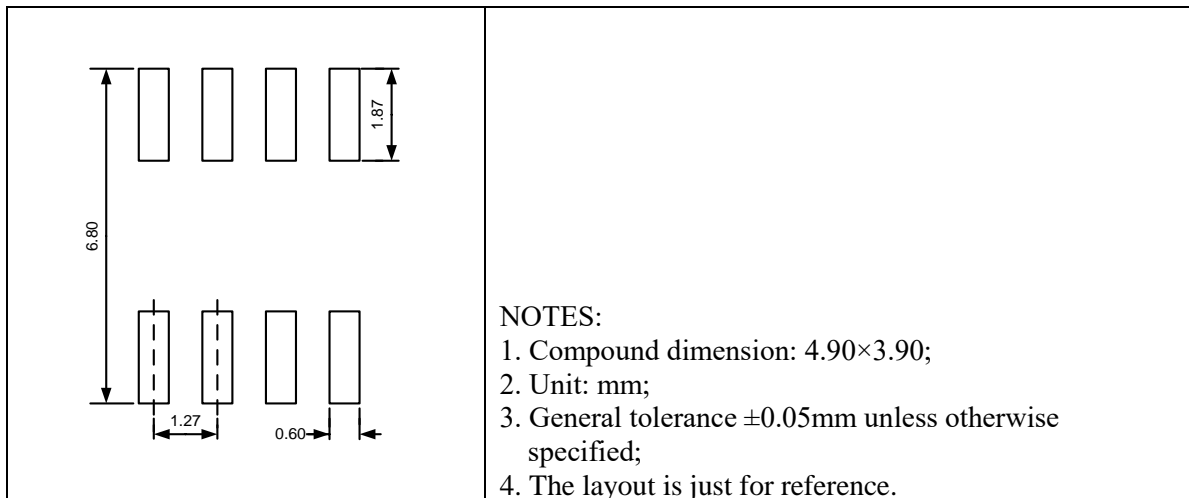

MSOP8

Outline Drawing

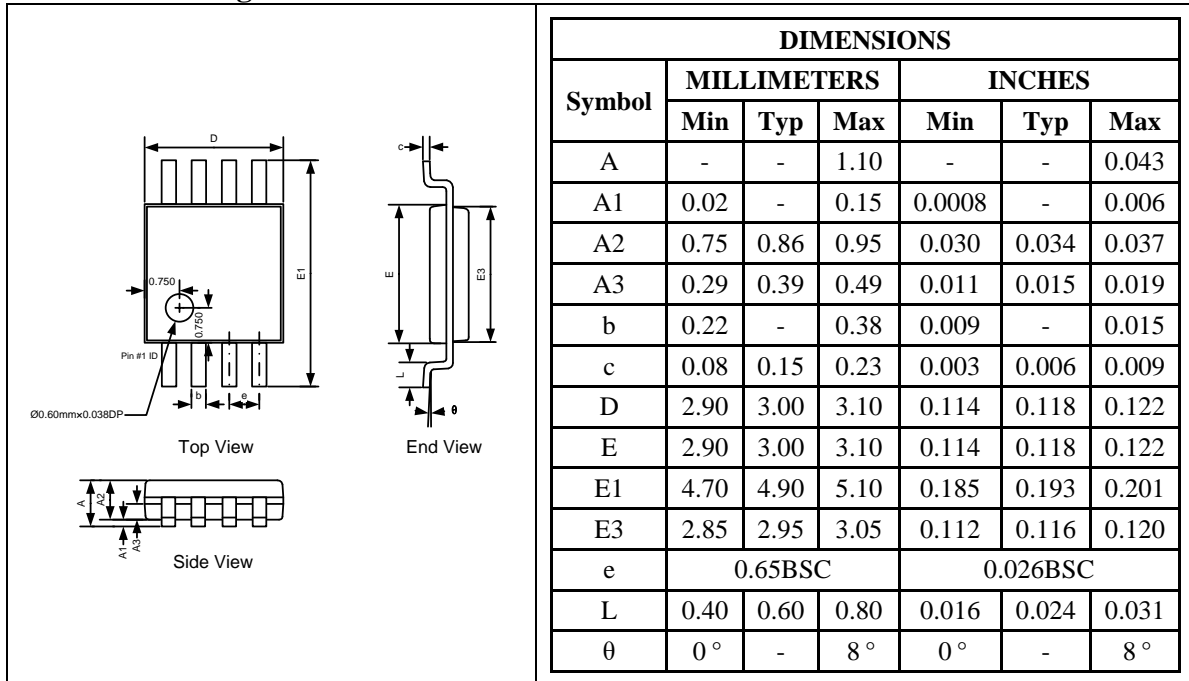

Land Pattern

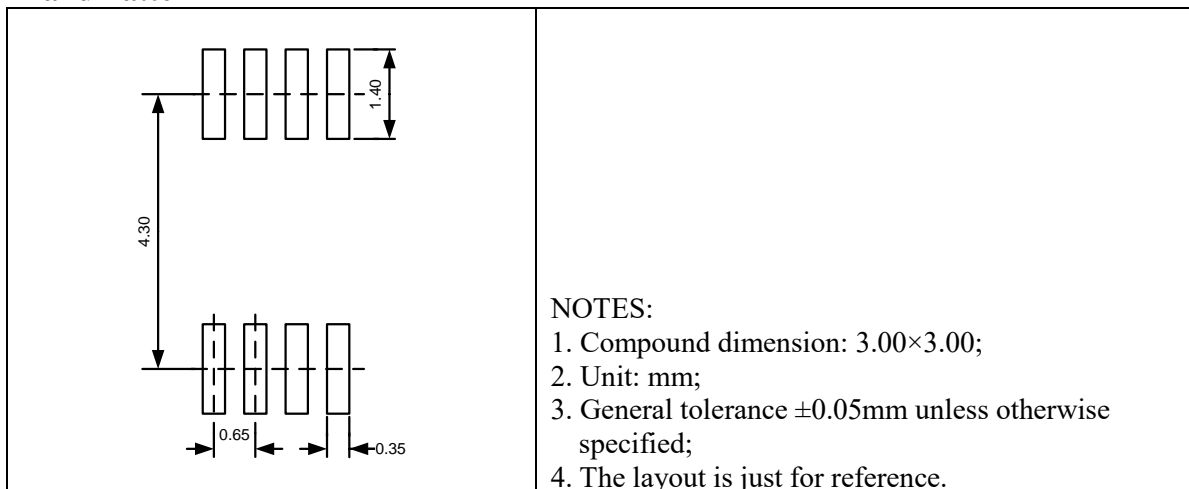

DFN8 3.0×3.0

Outline Drawing

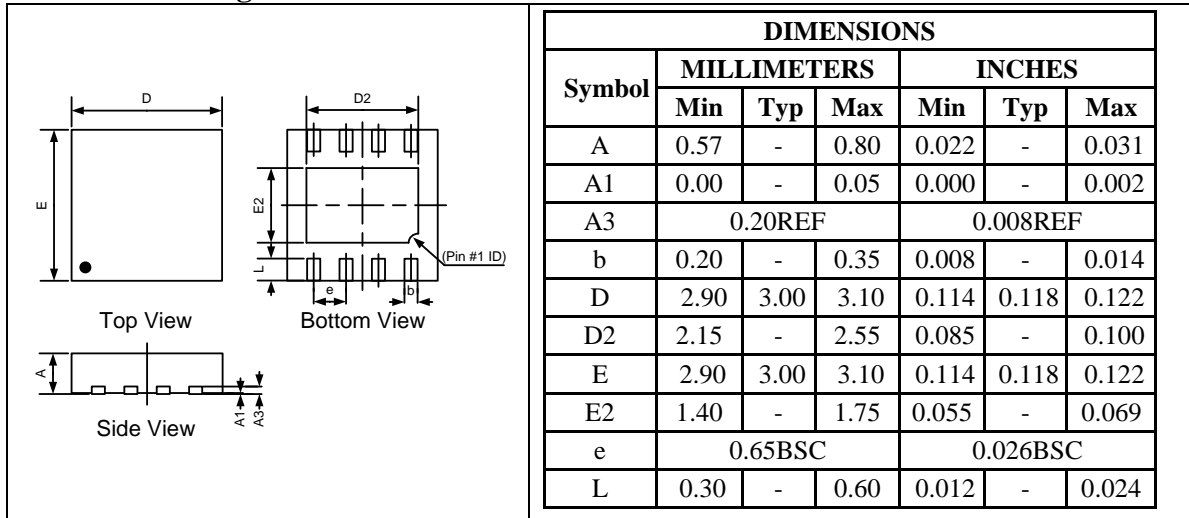

Land Pattern

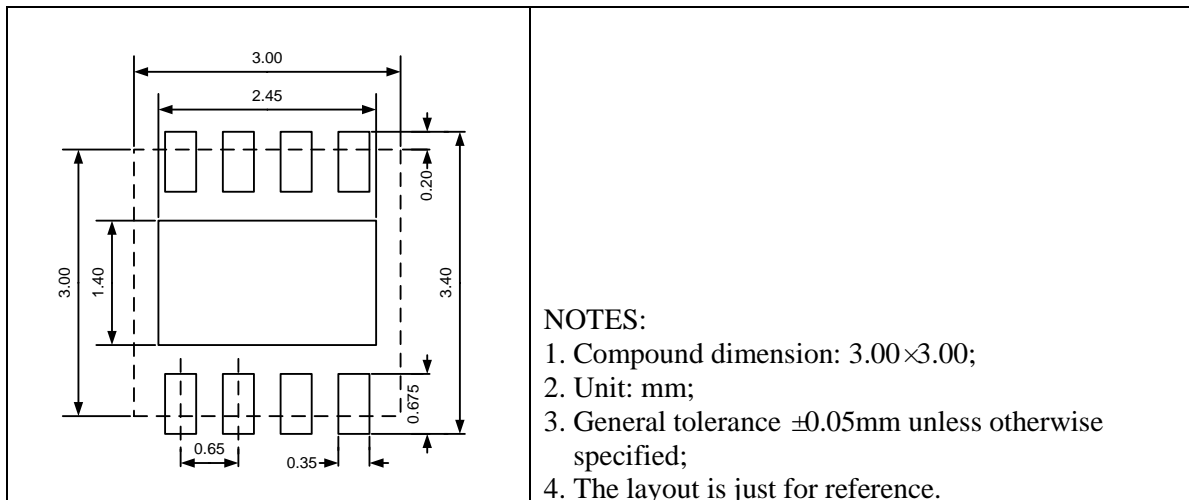

Packing Information

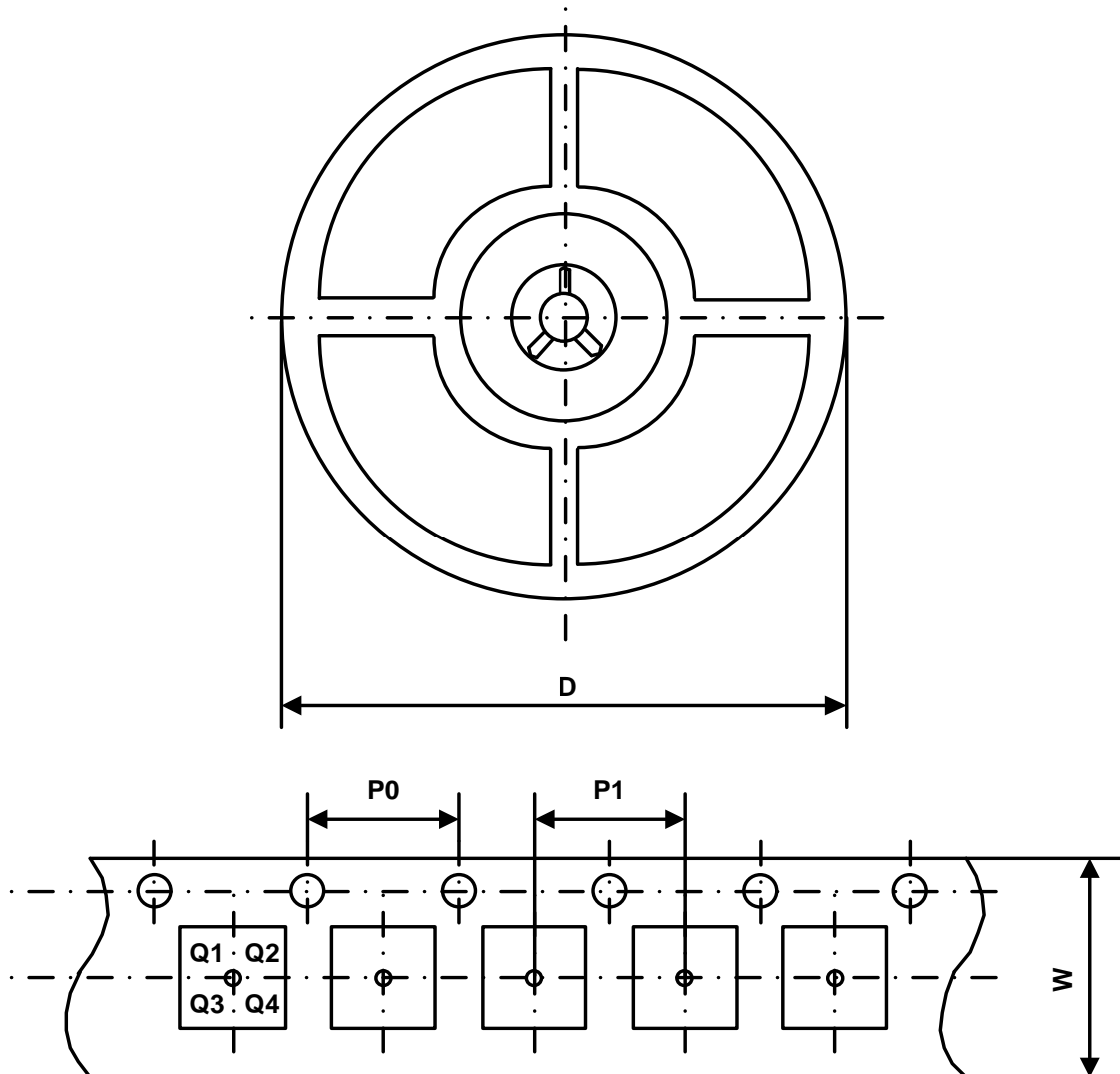

Part Number	Package Type	Carrier Width (W)	Pitch (P0)	Pitch (P1)	Reel Size (D)	PIN 1 Quadrant
UM3481DEESA	SOP8	12 mm	4 mm	8 mm	330 mm	Q1
UM3481DEEM8	MSOP8	12 mm	4 mm	8 mm	330 mm	Q1
UM3481DEEDA	DFN8 3.0×3.0	12 mm	4 mm	8 mm	330 mm	Q1
UM13082DEESA	SOP8	12 mm	4 mm	8 mm	330 mm	Q1
UM13082DEEM8	MSOP8	12 mm	4 mm	8 mm	330 mm	Q1
UM13082DEEDA	DFN8 3.0×3.0	12 mm	4 mm	8 mm	330 mm	Q1

GREEN COMPLIANCE

Union Semiconductor is committed to environmental excellence in all aspects of its operations including meeting or exceeding regulatory requirements with respect to the use of hazardous substances. Numerous successful programs have been implemented to reduce the use of hazardous substances and/or emissions.

All Union components are compliant with the RoHS directive, which helps to support customers in their compliance with environmental directives. For more green compliance information, please visit:

<https://www.union-ic.com/Quality.html>

IMPORTANT NOTICE

The information in this document has been carefully reviewed and is believed to be accurate. Nonetheless, this document is subject to change without notice. Union assumes no responsibility for any inaccuracies that may be contained in this document, and makes no commitment to update or to keep current the contained information, or to notify a person or organization of any update. Union reserves the right to make changes, at any time, in order to improve reliability, function or design and to attempt to supply the best product possible.