

具有可配置电压转换和三态输出的 8 位 双电源总线收发器

UM74AVC8TX245UO TSSOP24
UM74AVC8TX245QA QFN24 2.0×4.0
UM74AVC8TX245QB QFN24 3.5×5.5

1 描述

UM74AVC8TX245 旨在实现数据总线间的异步通信。根据方向控制输入 (DIR1 和 DIR2) 的逻辑电平, 此器件将数据从 A 总线传输至 B 总线, 或者将数据从 B 总线传输至 A 总线。输出使能 (\overline{OE}) 输入可用于禁用输出, 从而有效隔离总线。

UM74AVC8TX245 旨在使控制引脚 (DIR 和 \overline{OE}) 以 V_{CCA} 电压为基准。该器件专用于使用 I_{OFF} 的局部断电应用。当器件断电时, I_{OFF} 电路将会禁用输出。这会抑制电流反流到器件中, 从而防止损坏器件。 V_{CC} 隔离功能旨在确保当任一 V_{CC} 输入电源低于 100mV 时, 所有电平转换器输出都将禁用并处于高阻抗状态。要在上电或断电期间将该器件的 I/O 置于高阻抗状态, 请通过一个上拉电阻将 \overline{OE} 连接至 V_{CCA} ; 该电阻的最小值由驱动器的电流灌入能力决定。

UM74AVC8TX245 系列采用 TSSOP24、QFN24 2.0×4.0 和 QFN24 3.5×5.5 封装。

2 应用

- 企业与通信
- 工业
- 个人电子产品
- 无线基础设施
- 楼宇自动化
- 销售终端

3 特性

- 控制管脚输入 V_{IH}/V_{IL} 电平以 V_{CCA} 为基准
- 多向控制引脚, 支持同步升降转换
- I_{OFF} 支持局部断电应用
- V_{CC} 隔离特性--如果任何一个 V_{CC} 输入在接地 (GND) 上, 所有输出呈高阻态
- 完全可配置的双轨设计, 支持各个端口在 1V 至 3.6V 的整个电源电压范围内运行
- 向后兼容 UM74AVC8T245 器件
- 从 1.8V 转换到 3.3V 时, 支持高达 400Mbps 的转换速率
- 闩锁 (Latch-up) 性能超过 800mA, 符合 JESD 78, Class II 规范
- ESD 保护性能
 - $\pm 8kV$ 人体放电模型
 - $\pm 2kV$ 充电器件模型

4 Typical Application Schematic

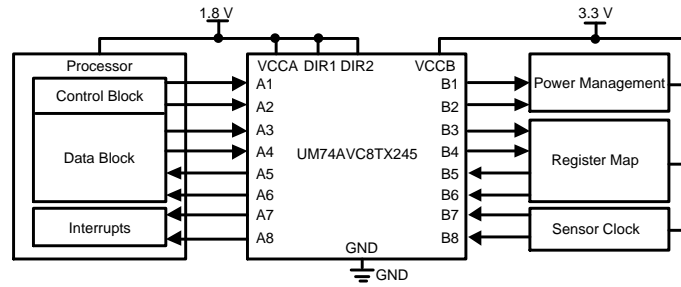

5 Ordering Information

Part Number	Mark Code	Package Type	Shipping Qty
UM74AVC8TX245UO	8TX245UO	TSSOP24	3000pcs/13Inch Tape & Reel
UM74AVC8TX245QA	8TX245	QFN24 2.0×4.0	3000pcs/7Inch Tape & Reel
UM74AVC8TX245QB	8TX245	QFN24 3.5×5.5	3000pcs/13Inch Tape & Reel

6 Pin Configuration and Function

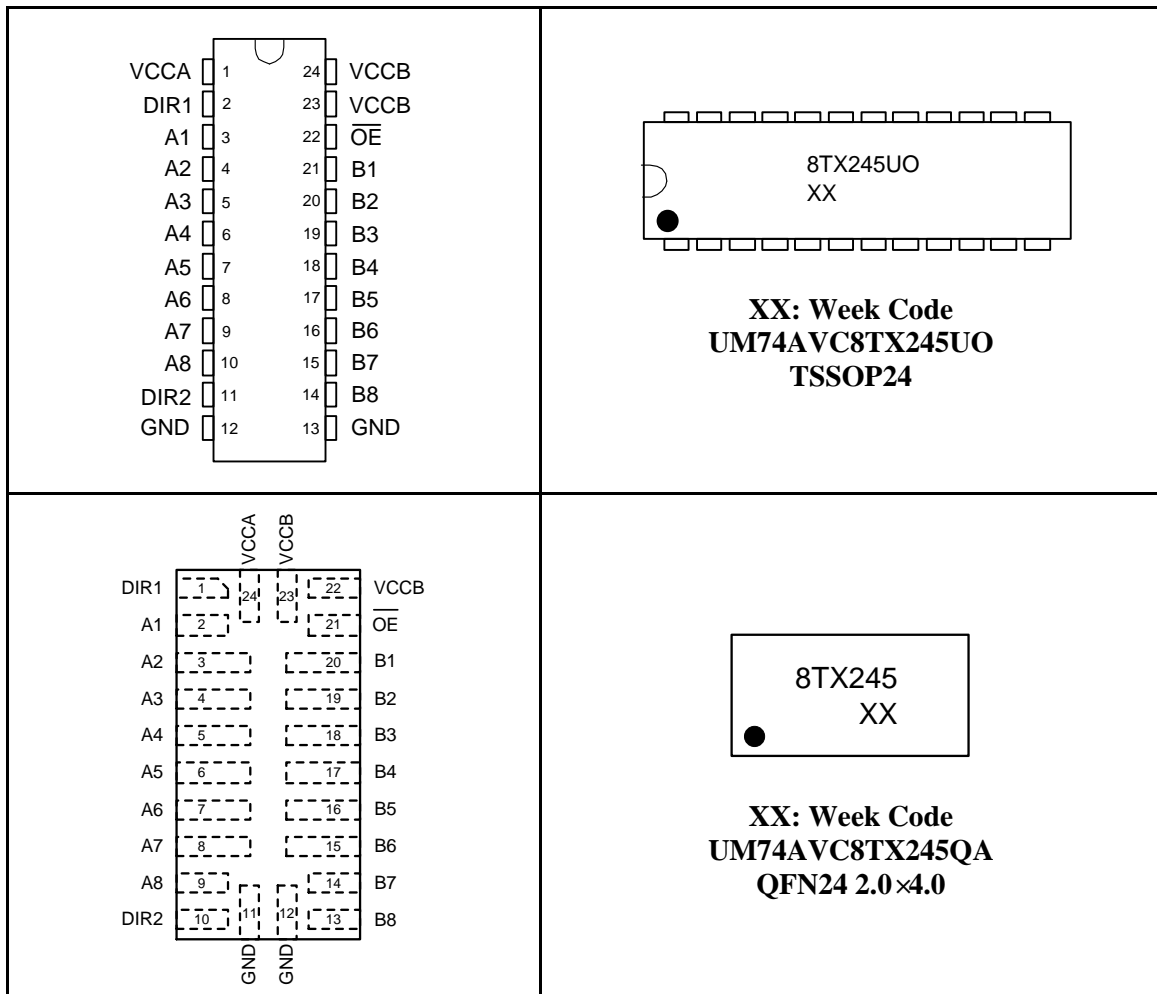

6 Pin Configuration and Function (continued)

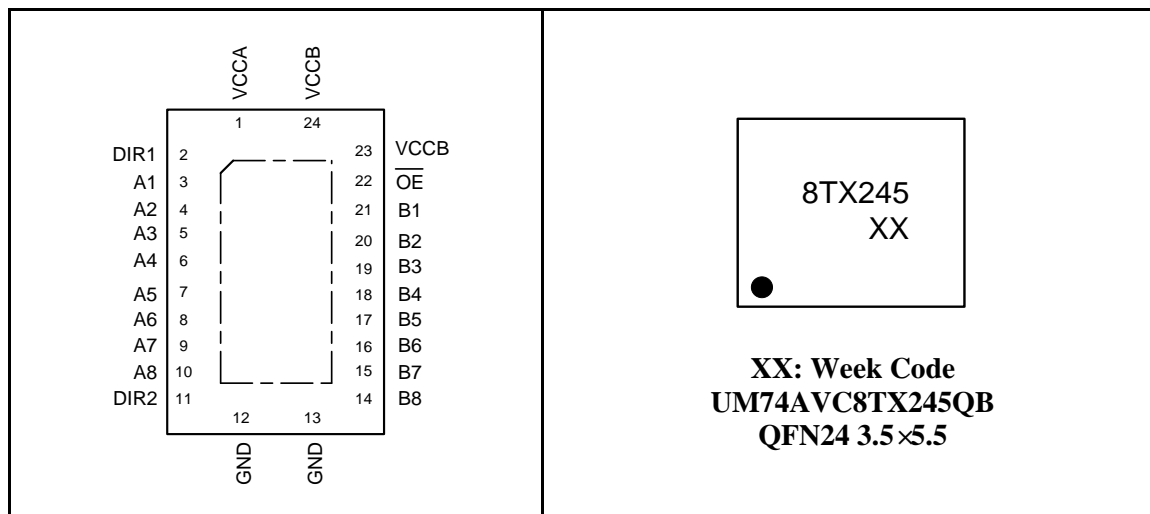

Table 6-1. Pin Functions

Pin Name	Pin No.		Function
	TSSOP24, QFN24 3.5x5.5	QFN24 2.0x4.0	
VCCA	1	24	A-port supply voltage. $1V \leq V_{CCA} \leq 3.6V$.
DIR1	2	1	Direction-control signal 1. Referenced to V_{CCA} .
A1	3	2	Input/output A1. Referenced to V_{CCA} .
A2	4	3	Input/output A2. Referenced to V_{CCA} .
A3	5	4	Input/output A3. Referenced to V_{CCA} .
A4	6	5	Input/output A4. Referenced to V_{CCA} .
A5	7	6	Input/output A5. Referenced to V_{CCA} .
A6	8	7	Input/output A6. Referenced to V_{CCA} .
A7	9	8	Input/output A7. Referenced to V_{CCA} .
A8	10	9	Input/output A8. Referenced to V_{CCA} .
DIR2	11	10	Direction-control signal 2. Referenced to V_{CCA} . Tie to GND to maintain backward compatibility with UM74AVC8T245 device.
GND	12-13	11-12	Ground.
B8	14	13	Input/output B8. Referenced to V_{CCB} .
B7	15	14	Input/output B7. Referenced to V_{CCB} .

6 Pin Configuration and Function (continued)

Table 6-1. Pin Functions

Pin Name	Pin No.		Function
	TSSOP24, QFN24 3.5×5.5	QFN24 2.0×4.0	
B6	16	15	Input/output B6. Referenced to V_{CCB} .
B5	17	16	Input/output B5. Referenced to V_{CCB} .
B4	18	17	Input/output B4. Referenced to V_{CCB} .
B3	19	18	Input/output B3. Referenced to V_{CCB} .
B2	20	19	Input/output B2. Referenced to V_{CCB} .
B1	21	20	Input/output B1. Referenced to V_{CCB} .
\overline{OE}	22	21	Output Enable. Pull to GND to enable all outputs. Pull to V_{CCA} to place all outputs in high-impedance mode. Referenced to V_{CCA} .
VCCB	23-24	22-23	B-port supply voltage. $1V \leq V_{CCB} \leq 3.6V$.

7 Specifications

7.1 Absolute Maximum Ratings (Note 1)

Symbol	Parameter		Value	Unit
V _{CCA}	Supply Voltage		-0.5 to +4.6	V
V _{CCB}	Supply Voltage		-0.5 to +4.6	V
V _I	Input Voltage (Note 2)	A ports	-0.5 to +4.6	V
		B ports	-0.5 to +4.6	
		Control inputs	-0.5 to +4.6	
V _O	Voltage applied to any output in the high-impedance or Power-Off State (Note 2)	A ports	-0.5 to +4.6	V
		B ports	-0.5 to +4.6	
V _O	Voltage Range Applied to Any Output in the High or Low State (Note 2, 3)	A ports	-0.5 to (V _{CCA} +0.5)	V
		B ports	-0.5 to (V _{CCB} +0.5)	
V _{ESD}	Human-body model (HBM), per ANSI/ESDA/ JEDEC JS-001	All pins	±8	kV
	Charged-device model (CDM), per ANSI/ESDA/ JEDEC JS-002	All pins	±2	kV
I _{LU}	Latch up, per JEDEC JESD78	Class II	800	mA
I _{IK}	Input clamp current	V _I <0	-50	mA
I _{OK}	Output clamp current	V _O <0	-50	mA
I _O	Continuous Output Current		±50	mA
	Continuous Current through V _{CCA} , V _{CCB} , or GND		±100	mA
T _J	Operating Junction Temperature		-40 to +150	°C
T _{STG}	Storage Temperature		-65 to +150	°C

Note 1: Stresses beyond those listed under "Absolute Maximum Ratings" may cause permanent damage to the device. These are stress ratings only, and functional operation of the device at these or any other conditions beyond those indicated under "Recommended Operating Conditions" is not implied. Exposure to absolute-maximum-rated conditions for extended periods may affect device reliability.

Note 2: The input and output negative-voltage ratings may be exceeded if the input and output current ratings are observed.

Note 3: The output positive-voltage rating may be exceeded up to 4.6 V maximum if the output current rating is observed.

7.2 Recommended Operating Conditions (Note 1, 2, 3)

Over recommended operating free-air temperature range (unless otherwise noted).

Symbol	Parameter		V _{CCI}	V _{CCO}	Min	Max	Unit
V _{CCA}	Supply voltage				1	3.6	V
V _{CBB}					1	3.6	
V _{IH}	High-level input voltage	Data inputs	1V		V _{CCI} ×0.7		V
			1.1 V to 1.95 V		V _{CCI} ×0.65		
			1.95 V to 2.7 V		1.6		
			2.7V to 3.6 V		2		
V _{IL}	Low-level input voltage	Data inputs	1V		V _{CCI} ×0.3		V
			1.1 V to 1.95 V		V _{CCI} ×0.35		
			1.95 V to 2.7 V		0.7		
			2.7V to 3.6 V		0.8		
V _{IH}	High-level input voltage	Control inputs (DIR, \overline{OE}) referenced to V _{CCA}	1V		V _{CCI} ×0.7		V
			1.1 V to 1.95 V		V _{CCI} ×0.65		
			1.95 V to 2.7 V		1.6		
			2.7V to 3.6 V		2		
V _{IL}	Low-level input voltage	Control inputs (DIR, \overline{OE}) referenced to V _{CCA}	1V		V _{CCI} ×0.3		V
			1.1 V to 1.95 V		V _{CCI} ×0.35		
			1.95 V to 2.7 V		0.7		
			2.7V to 3.6 V		0.8		
V _I	Input voltage			0	3.6	V	
V _O	Output voltage	Active state			0	V _{CCO}	V
		Three-State			0	3.6	
I _{OH}	High-level output current			1.1V to 1.3 V	-3		mA
				1.4 V to 1.6 V	-6		
				1.65 V to 1.95 V	-8		
				2.3 V to 2.7 V	-9		
				3 V to 3.6 V	-12		
I _O L	Low-level output current			1.1V to 1.3 V	3		mA
				1.4 V to 1.6 V	6		
				1.65 V to 1.95 V	8		
				2.3 V to 2.7 V	9		
				3 V to 3.6 V	12		
Δt/ΔV	Input transition rise or fall rate				10	ns/V	
T _A	Operating free-air temperature				-40	125	°C

Note 1: V_{CCI} is the V_{CC} associated with the input port.

Note 2: V_{CCO} is the V_{CC} associated with the output port.

Note 3: All unused or driven (floating) data inputs (I/Os) of the device must be held at logic High or Low (preferably V_{CCI} or GND) to ensure proper device operation and minimize power.

7.3 Package Thermal Impedance

Symbol	Parameter		Value	Unit	
R _{θJA}	Junction-to-ambient thermal resistance		TSSOP24	100.6	°C/W
			QFN24 2.0×4.0	123.1	
			QFN24 3.5×5.5	48.3	
R _{θJC(top)}	Junction-to-case (top) thermal resistance		TSSOP24	44.7	°C/W
			QFN24 2.0×4.0	65	
			QFN24 3.5×5.5	46.1	
R _{θJB}	Junction-to-board thermal resistance		TSSOP24	55.8	°C/W
			QFN24 2.0×4.0	55.3	
			QFN24 3.5×5.5	26.1	

7.4 Electrical Characteristics (Note 1, 2)

Over recommended operating free-air temperature range (unless otherwise noted).

Parameter	Test Conditions	V _{CCA}	V _{CCB}	Min	Typ	Max	Unit
V _{OH}	I _{OH} =-100μA	1V to 3.6V	1V to 3.6V	V _{CCO} -0.2			V
	I _{OH} =-3mA			0.85	0.98		
	I _{OH} =-6mA			1			
	I _{OH} =-8mA			1.2			
	I _{OH} =-9mA			1.8			
	I _{OH} =-12mA			2.4			
V _{OL}	I _{OL} =100μA	1V to 3.6V	1V to 3.6V			0.2	V
	I _{OL} =3mA				0.1	0.25	
	I _{OL} =6mA					0.35	
	I _{OL} =8mA					0.45	
	I _{OL} =9mA					0.55	
	I _{OL} =12mA					0.7	
I _I Control inputs	V _I = V _{CCA} or GND	1V to 3.6V	1V to 3.6V	-1	0.1	1	μA
I _{OZ} A or B Port	V _O = V _{CCO} or GND, V _I = V _{CCI} or GND, \overline{OE} = V _{IH}	3.6V	3.6V	-5	0.1	5	μA
I _{OFF} A or B Port	V _I or V _O = 0 to 3.6V	0V	0V to 3.6V	-5	0.1	5	μA
		0V to 3.6V	0V	-5	0.1	5	
I _{CCA}	V _I =V _{CCI} or GND I _O =0	1V to 3.6V	1V to 3.6V			8	μA
		0V	3.6V	-2			
		3.6V	0V			8	
I _{CCB}	V _I =V _{CCB} or GND I _O =0	1V to 3.6V	1V to 3.6V			8	μA
		0V	3.6V			8	
		3.6V	0V	-2			
I _{CCA} +I _{CCB}	V _I =V _{CCI} or GND I _O =0	1V to 3.6V	1V to 3.6V			16	μA
C _I Control inputs	V _I = 3.3V or GND	3.3V	3.3V			7.5	pF
C _{IO} A or B Port	V _O = 3.3V or GND	3.3V	3.3V			8.5	pF

Note 1: V_{CCI} is the V_{CC} associated with the input port.

Note 2: V_{CCO} is the V_{CC} associated with the output port.

7.5 Switching Characteristics

Over recommended operating free-air temperature range, $V_{CCA} = 1V$.

Parameter	From (Input)	To (Output)	V_{CCB}	Min	Typ	Max	Unit
t_{PLH}, t_{PHL}	A	B	$V_{CCB}=1V$	0.5		30	ns
			$V_{CCB}=1.2V \pm 0.1V$	0.5		20	
			$V_{CCB}=1.5V \pm 0.1V$	0.5		17	
			$V_{CCB}=1.8V \pm 0.15V$	0.5		15	
			$V_{CCB}=2.5V \pm 0.2V$	0.5		15	
			$V_{CCB}=3.3V \pm 0.3V$	0.5		17	
t_{PLH}, t_{PHL}	B	A	$V_{CCB}=1V$	0.5		30	ns
			$V_{CCB}=1.2V \pm 0.1V$	0.5		20	
			$V_{CCB}=1.5V \pm 0.1V$	0.5		17	
			$V_{CCB}=1.8V \pm 0.15V$	0.5		15	
			$V_{CCB}=2.5V \pm 0.2V$	0.5		17	
			$V_{CCB}=3.3V \pm 0.3V$	0.5		17	
t_{pZH}, t_{pZL}	\overline{OE}	A	$V_{CCB}=1V$	0.5		35	ns
			$V_{CCB}=1.2V \pm 0.1V$	0.5		35	
			$V_{CCB}=1.5V \pm 0.1V$	0.5		35	
			$V_{CCB}=1.8V \pm 0.15V$	0.5		35	
			$V_{CCB}=2.5V \pm 0.2V$	0.5		35	
			$V_{CCB}=3.3V \pm 0.3V$	0.5		35	
t_{pZH}, t_{pZL}	\overline{OE}	B	$V_{CCB}=1V$	0.5		40	ns
			$V_{CCB}=1.2V \pm 0.1V$	0.5		35	
			$V_{CCB}=1.5V \pm 0.1V$	0.5		35	
			$V_{CCB}=1.8V \pm 0.15V$	0.5		35	
			$V_{CCB}=2.5V \pm 0.2V$	0.5		35	
			$V_{CCB}=3.3V \pm 0.3V$	0.5		35	
t_{pHZ}, t_{pLZ}	\overline{OE}	A	$V_{CCB}=1V$	0.5		35	ns
			$V_{CCB}=1.2V \pm 0.1V$	0.5		35	
			$V_{CCB}=1.5V \pm 0.1V$	0.5		35	
			$V_{CCB}=1.8V \pm 0.15V$	0.5		35	
			$V_{CCB}=2.5V \pm 0.2V$	0.5		35	
			$V_{CCB}=3.3V \pm 0.3V$	0.5		35	
t_{pHZ}, t_{pLZ}	\overline{OE}	B	$V_{CCB}=1V$	0.5		40	ns
			$V_{CCB}=1.2V \pm 0.1V$	0.5		35	
			$V_{CCB}=1.5V \pm 0.1V$	0.5		35	
			$V_{CCB}=1.8V \pm 0.15V$	0.5		35	
			$V_{CCB}=2.5V \pm 0.2V$	0.5		35	
			$V_{CCB}=3.3V \pm 0.3V$	0.5		35	

7.5 Switching Characteristics (continued)

Over recommended operating free-air temperature range, $V_{CCA} = 1.2V \pm 0.1V$.

Parameter	From (Input)	To (Output)	V_{CCB}	Min	Typ	Max	Unit
t_{PLH}, t_{PHL}	A	B	$V_{CCB}=1V$	0.5		23	ns
			$V_{CCB}=1.2V \pm 0.1V$	0.5		15	
			$V_{CCB}=1.5V \pm 0.1V$	0.5		10	
			$V_{CCB}=1.8V \pm 0.15V$	0.5		9	
			$V_{CCB}=2.5V \pm 0.2V$	0.5		7	
			$V_{CCB}=3.3V \pm 0.3V$	0.5		7.5	
t_{PLH}, t_{PHL}	B	A	$V_{CCB}=1V$	0.5		23	ns
			$V_{CCB}=1.2V \pm 0.1V$	0.5		15	
			$V_{CCB}=1.5V \pm 0.1V$	0.5		13	
			$V_{CCB}=1.8V \pm 0.15V$	0.5		11	
			$V_{CCB}=2.5V \pm 0.2V$	0.5		8	
			$V_{CCB}=3.3V \pm 0.3V$	0.5		7	
t_{pZH}, t_{pZL}	\overline{OE}	A	$V_{CCB}=1V$	0.5		30	ns
			$V_{CCB}=1.2V \pm 0.1V$	0.5		30	
			$V_{CCB}=1.5V \pm 0.1V$	0.5		30	
			$V_{CCB}=1.8V \pm 0.15V$	0.5		30	
			$V_{CCB}=2.5V \pm 0.2V$	0.5		30	
			$V_{CCB}=3.3V \pm 0.3V$	0.5		30	
t_{pZH}, t_{pZL}	\overline{OE}	B	$V_{CCB}=1V$	0.5		30	ns
			$V_{CCB}=1.2V \pm 0.1V$	0.5		25	
			$V_{CCB}=1.5V \pm 0.1V$	0.5		22	
			$V_{CCB}=1.8V \pm 0.15V$	0.5		19	
			$V_{CCB}=2.5V \pm 0.2V$	0.5		17	
			$V_{CCB}=3.3V \pm 0.3V$	0.5		17	
t_{pHZ}, t_{pLZ}	\overline{OE}	A	$V_{CCB}=1V$	0.5		35	ns
			$V_{CCB}=1.2V \pm 0.1V$	0.5		30	
			$V_{CCB}=1.5V \pm 0.1V$	0.5		30	
			$V_{CCB}=1.8V \pm 0.15V$	0.5		30	
			$V_{CCB}=2.5V \pm 0.2V$	0.5		30	
			$V_{CCB}=3.3V \pm 0.3V$	0.5		30	
t_{pHZ}, t_{pLZ}	\overline{OE}	B	$V_{CCB}=1V$	0.5		35	ns
			$V_{CCB}=1.2V \pm 0.1V$	0.5		30	
			$V_{CCB}=1.5V \pm 0.1V$	0.5		30	
			$V_{CCB}=1.8V \pm 0.15V$	0.5		30	
			$V_{CCB}=2.5V \pm 0.2V$	0.5		30	
			$V_{CCB}=3.3V \pm 0.3V$	0.5		30	

7.5 Switching Characteristics (continued)

Over recommended operating free-air temperature range, $V_{CCA} = 1.5V \pm 0.1V$.

Parameter	From (Input)	To (Output)	V_{CCB}	Min	Typ	Max	Unit
t_{PLH}, t_{PHL}	A	B	$V_{CCB}=1V$	0.5		18	ns
			$V_{CCB}=1.2V \pm 0.1V$	0.5		13	
			$V_{CCB}=1.5V \pm 0.1V$	0.5		9	
			$V_{CCB}=1.8V \pm 0.15V$	0.5		7	
			$V_{CCB}=2.5V \pm 0.2V$	0.5		6	
			$V_{CCB}=3.3V \pm 0.3V$	0.5		5.5	
t_{PLH}, t_{PHL}	B	A	$V_{CCB}=1V$	0.5		17	ns
			$V_{CCB}=1.2V \pm 0.1V$	0.5		11	
			$V_{CCB}=1.5V \pm 0.1V$	0.5		9	
			$V_{CCB}=1.8V \pm 0.15V$	0.5		7.5	
			$V_{CCB}=2.5V \pm 0.2V$	0.5		6	
			$V_{CCB}=3.3V \pm 0.3V$	0.5		5	
t_{pZH}, t_{pZL}	\overline{OE}	A	$V_{CCB}=1V$	0.5		23	ns
			$V_{CCB}=1.2V \pm 0.1V$	0.5		23	
			$V_{CCB}=1.5V \pm 0.1V$	0.5		23	
			$V_{CCB}=1.8V \pm 0.15V$	0.5		23	
			$V_{CCB}=2.5V \pm 0.2V$	0.5		23	
			$V_{CCB}=3.3V \pm 0.3V$	0.5		23	
t_{pZH}, t_{pZL}	\overline{OE}	B	$V_{CCB}=1V$	0.5		27	ns
			$V_{CCB}=1.2V \pm 0.1V$	0.5		24	
			$V_{CCB}=1.5V \pm 0.1V$	0.5		17	
			$V_{CCB}=1.8V \pm 0.15V$	0.5		15	
			$V_{CCB}=2.5V \pm 0.2V$	0.5		12	
			$V_{CCB}=3.3V \pm 0.3V$	0.5		11	
t_{pHZ}, t_{pLZ}	\overline{OE}	A	$V_{CCB}=1V$	0.5		34	ns
			$V_{CCB}=1.2V \pm 0.1V$	0.5		34	
			$V_{CCB}=1.5V \pm 0.1V$	0.5		34	
			$V_{CCB}=1.8V \pm 0.15V$	0.5		34	
			$V_{CCB}=2.5V \pm 0.2V$	0.5		34	
			$V_{CCB}=3.3V \pm 0.3V$	0.5		34	
t_{pHZ}, t_{pLZ}	\overline{OE}	B	$V_{CCB}=1V$	0.5		45	ns
			$V_{CCB}=1.2V \pm 0.1V$	0.5		40	
			$V_{CCB}=1.5V \pm 0.1V$	0.5		35	
			$V_{CCB}=1.8V \pm 0.15V$	0.5		31	
			$V_{CCB}=2.5V \pm 0.2V$	0.5		28	
			$V_{CCB}=3.3V \pm 0.3V$	0.5		25	

7.5 Switching Characteristics (continued)

 Over recommended operating free-air temperature range, $V_{CCA} = 1.8V \pm 0.15V$.

Parameter	From (Input)	To (Output)	V_{CCB}	Min	Typ	Max	Unit
t_{PLH}, t_{PHL}	A	B	$V_{CCB}=1V$	0.5		16	ns
			$V_{CCB}=1.2V \pm 0.1V$	0.5		11	
			$V_{CCB}=1.5V \pm 0.1V$	0.5		8	
			$V_{CCB}=1.8V \pm 0.15V$	0.5		7	
			$V_{CCB}=2.5V \pm 0.2V$	0.5		6	
			$V_{CCB}=3.3V \pm 0.3V$	0.5		5	
t_{PLH}, t_{PHL}	B	A	$V_{CCB}=1V$	0.5		16	ns
			$V_{CCB}=1.2V \pm 0.1V$	0.5		10	
			$V_{CCB}=1.5V \pm 0.1V$	0.5		7	
			$V_{CCB}=1.8V \pm 0.15V$	0.5		7	
			$V_{CCB}=2.5V \pm 0.2V$	0.5		5	
			$V_{CCB}=3.3V \pm 0.3V$	0.5		4	
t_{PZH}, t_{PZL}	\overline{OE}	A	$V_{CCB}=1V$	0.5		17	ns
			$V_{CCB}=1.2V \pm 0.1V$	0.5		17	
			$V_{CCB}=1.5V \pm 0.1V$	0.5		17	
			$V_{CCB}=1.8V \pm 0.15V$	0.5		17	
			$V_{CCB}=2.5V \pm 0.2V$	0.5		17	
			$V_{CCB}=3.3V \pm 0.3V$	0.5		17	
t_{PZH}, t_{PZL}	\overline{OE}	B	$V_{CCB}=1V$	0.5		23	ns
			$V_{CCB}=1.2V \pm 0.1V$	0.5		23	
			$V_{CCB}=1.5V \pm 0.1V$	0.5		15	
			$V_{CCB}=1.8V \pm 0.15V$	0.5		13	
			$V_{CCB}=2.5V \pm 0.2V$	0.5		10	
			$V_{CCB}=3.3V \pm 0.3V$	0.5		9	
t_{PHZ}, t_{PLZ}	\overline{OE}	A	$V_{CCB}=1V$	0.5		30	ns
			$V_{CCB}=1.2V \pm 0.1V$	0.5		30	
			$V_{CCB}=1.5V \pm 0.1V$	0.5		30	
			$V_{CCB}=1.8V \pm 0.15V$	0.5		30	
			$V_{CCB}=2.5V \pm 0.2V$	0.5		30	
			$V_{CCB}=3.3V \pm 0.3V$	0.5		30	
t_{PHZ}, t_{PLZ}	\overline{OE}	B	$V_{CCB}=1V$	0.5		30	ns
			$V_{CCB}=1.2V \pm 0.1V$	0.5		30	
			$V_{CCB}=1.5V \pm 0.1V$	0.5		30	
			$V_{CCB}=1.8V \pm 0.15V$	0.5		30	
			$V_{CCB}=2.5V \pm 0.2V$	0.5		30	
			$V_{CCB}=3.3V \pm 0.3V$	0.5		30	

7.5 Switching Characteristics (continued)

 Over recommended operating free-air temperature range, $V_{CCA} = 2.5V \pm 0.2V$.

Parameter	From (Input)	To (Output)	V_{CCB}	Min	Typ	Max	Unit
t_{PLH}, t_{PHL}	A	B	$V_{CCB}=1V$	0.5		15	ns
			$V_{CCB}=1.2V \pm 0.1V$	0.5		8	
			$V_{CCB}=1.5V \pm 0.1V$	0.5		6	
			$V_{CCB}=1.8V \pm 0.15V$	0.5		5.5	
			$V_{CCB}=2.5V \pm 0.2V$	0.5		5	
			$V_{CCB}=3.3V \pm 0.3V$	0.5		4	
t_{PLH}, t_{PHL}	B	A	$V_{CCB}=1V$	0.5		15	ns
			$V_{CCB}=1.2V \pm 0.1V$	0.5		7.5	
			$V_{CCB}=1.5V \pm 0.1V$	0.5		6	
			$V_{CCB}=1.8V \pm 0.15V$	0.5		5.5	
			$V_{CCB}=2.5V \pm 0.2V$	0.5		5	
			$V_{CCB}=3.3V \pm 0.3V$	0.5		4	
t_{PZH}, t_{PZL}	\overline{OE}	A	$V_{CCB}=1V$	0.5		16	ns
			$V_{CCB}=1.2V \pm 0.1V$	0.5		12	
			$V_{CCB}=1.5V \pm 0.1V$	0.5		12	
			$V_{CCB}=1.8V \pm 0.15V$	0.5		12	
			$V_{CCB}=2.5V \pm 0.2V$	0.5		12	
			$V_{CCB}=3.3V \pm 0.3V$	0.5		12	
t_{PZH}, t_{PZL}	\overline{OE}	B	$V_{CCB}=1V$	0.5		21	ns
			$V_{CCB}=1.2V \pm 0.1V$	0.5		18	
			$V_{CCB}=1.5V \pm 0.1V$	0.5		14	
			$V_{CCB}=1.8V \pm 0.15V$	0.5		12	
			$V_{CCB}=2.5V \pm 0.2V$	0.5		9	
			$V_{CCB}=3.3V \pm 0.3V$	0.5		8	
t_{PHZ}, t_{PLZ}	\overline{OE}	A	$V_{CCB}=1V$	0.5		25	ns
			$V_{CCB}=1.2V \pm 0.1V$	0.5		25	
			$V_{CCB}=1.5V \pm 0.1V$	0.5		25	
			$V_{CCB}=1.8V \pm 0.15V$	0.5		25	
			$V_{CCB}=2.5V \pm 0.2V$	0.5		25	
			$V_{CCB}=3.3V \pm 0.3V$	0.5		25	
t_{PHZ}, t_{PLZ}	\overline{OE}	B	$V_{CCB}=1V$	0.5		35	ns
			$V_{CCB}=1.2V \pm 0.1V$	0.5		32	
			$V_{CCB}=1.5V \pm 0.1V$	0.5		30	
			$V_{CCB}=1.8V \pm 0.15V$	0.5		28	
			$V_{CCB}=2.5V \pm 0.2V$	0.5		25	
			$V_{CCB}=3.3V \pm 0.3V$	0.5		23	

7.5 Switching Characteristics (continued)

Over recommended operating free-air temperature range, $V_{CCA} = 3.3V \pm 0.3V$.

Parameter	From (Input)	To (Output)	V_{CCB}	Min	Typ	Max	Unit
t_{PLH}, t_{PHL}	A	B	$V_{CCB}=1V$	0.5		16	ns
			$V_{CCB}=1.2V \pm 0.1V$	0.5		7	
			$V_{CCB}=1.5V \pm 0.1V$	0.5		5	
			$V_{CCB}=1.8V \pm 0.15V$	0.5		4	
			$V_{CCB}=2.5V \pm 0.2V$	0.5		4	
			$V_{CCB}=3.3V \pm 0.3V$	0.5		4	
t_{PLH}, t_{PHL}	B	A	$V_{CCB}=1V$	0.5		16	ns
			$V_{CCB}=1.2V \pm 0.1V$	0.5		7	
			$V_{CCB}=1.5V \pm 0.1V$	0.5		6	
			$V_{CCB}=1.8V \pm 0.15V$	0.5		5	
			$V_{CCB}=2.5V \pm 0.2V$	0.5		4	
			$V_{CCB}=3.3V \pm 0.3V$	0.5		4	
t_{pZH}, t_{pZL}	\overline{OE}	A	$V_{CCB}=1V$	0.5		15.5	ns
			$V_{CCB}=1.2V \pm 0.1V$	0.5		11.5	
			$V_{CCB}=1.5V \pm 0.1V$	0.5		10	
			$V_{CCB}=1.8V \pm 0.15V$	0.5		10	
			$V_{CCB}=2.5V \pm 0.2V$	0.5		10	
			$V_{CCB}=3.3V \pm 0.3V$	0.5		10	
t_{pZH}, t_{pZL}	\overline{OE}	B	$V_{CCB}=1V$	0.5		50	ns
			$V_{CCB}=1.2V \pm 0.1V$	0.5		20	
			$V_{CCB}=1.5V \pm 0.1V$	0.5		14	
			$V_{CCB}=1.8V \pm 0.15V$	0.5		11	
			$V_{CCB}=2.5V \pm 0.2V$	0.5		8	
			$V_{CCB}=3.3V \pm 0.3V$	0.5		7	
t_{pHZ}, t_{pLZ}	\overline{OE}	A	$V_{CCB}=1V$	0.5		22	ns
			$V_{CCB}=1.2V \pm 0.1V$	0.5		22	
			$V_{CCB}=1.5V \pm 0.1V$	0.5		22	
			$V_{CCB}=1.8V \pm 0.15V$	0.5		22	
			$V_{CCB}=2.5V \pm 0.2V$	0.5		22	
			$V_{CCB}=3.3V \pm 0.3V$	0.5		22	
t_{pHZ}, t_{pLZ}	\overline{OE}	B	$V_{CCB}=1V$	0.5		36	ns
			$V_{CCB}=1.2V \pm 0.1V$	0.5		33	
			$V_{CCB}=1.5V \pm 0.1V$	0.5		30	
			$V_{CCB}=1.8V \pm 0.15V$	0.5		27	
			$V_{CCB}=2.5V \pm 0.2V$	0.5		25	
			$V_{CCB}=3.3V \pm 0.3V$	0.5		23	

7.6 Operating Characteristics (Note 1)

$T_A=25^{\circ}\text{C}$.

Parameter			Test Conditions	$V_{CCA} =$ $V_{CCB} =$ 1V	$V_{CCA} =$ $V_{CCB} =$ 1.2V	$V_{CCA} =$ $V_{CCB} =$ 1.5V	$V_{CCA} =$ $V_{CCB} =$ 1.8V	$V_{CCA} =$ $V_{CCB} =$ 2.5V	$V_{CCA} =$ $V_{CCB} =$ 3.3V	Unit
				Typ	Typ	Typ	Typ	Typ	Typ	
C_{PDA}	A to B	Outputs enabled	$C_L = 0,$ $f=10\text{MHz},$ $t_r = t_f = 1\text{ns}$	2	2.2	2.3	2.5	2.7	3.5	pF
		Outputs disabled		1	1	1	1	1	1	
	B to A	Outputs enabled		12	12	12	12	13	13.5	
		Outputs disabled		1	1	1	1	1	1	
C_{PDB}	A to B	Outputs enabled		12	12	12	12	13	13.5	
		Outputs disabled		1	1	1	1	1	1	
	B to A	Outputs enabled		2	2.2	2.3	2.5	2.7	3.5	
		Outputs disabled		1	1	1	1	1	1	

Note 1: C_{PDA} and C_{PDB} are power dissipation capacitance per transceiver.

8 Parameter Measurement Information

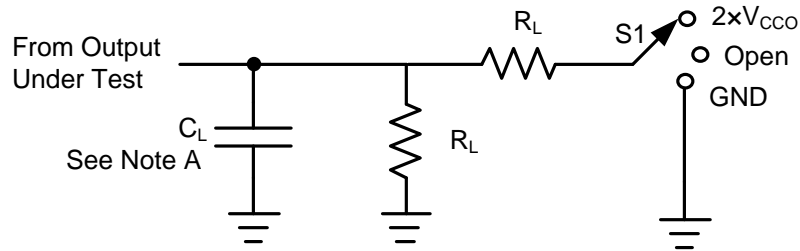

Figure 8-1. Load Circuit

Parameter	V _{CCO}	C _L	R _L	S1	V _{TP}
t _{PD}	1V to 3.6V	15pF	2kΩ	Open	N/A
t _{PLZ} , t _{PZL}	1V to 1.6V	15pF	2kΩ	2 × V _{CCO}	0.1V
	1.65V to 2.7V	15pF	2kΩ	2 × V _{CCO}	0.15V
	3V to 3.6V	15pF	2kΩ	2 × V _{CCO}	0.3V
t _{PHZ} , t _{PZH}	1V to 1.6V	15pF	2kΩ	GND	0.1V
	1.65V to 2.7V	15pF	2kΩ	GND	0.15V
	3V to 3.6V	15pF	2kΩ	GND	0.3V

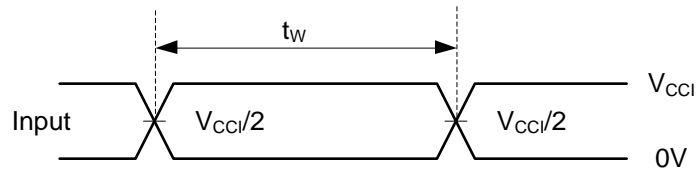

Figure 8-2. Voltage Waveforms Pulse Duration

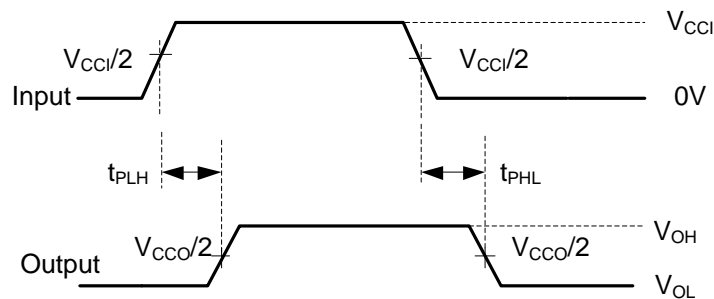

Figure 8-3. Voltage Waveforms Propagation Delay Times

8 Parameter Measurement Information (continued)

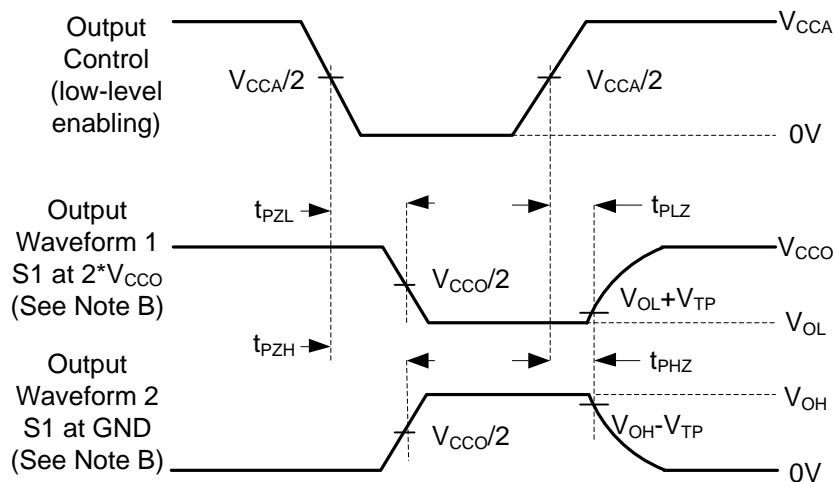

Figure 8-4. Voltage Waveforms Enable and Disable Times

Notes:

- A. C_L includes probe and jig capacitance.
- B. Waveform 1 is for an output with internal conditions such that the output is low, except when disabled by the output control. Waveform 2 is for an output with internal conditions such that the output is high, except when disabled by the output control.
- C. All input pulses are supplied by generators having the following characteristics: $PRR \leq 10$ MHz, $Z_O = 50\Omega$, $dv/dt \geq 1V/ns$.
- D. The outputs are measured one at a time, with one transition per measurement.
- E. t_{PLZ} and t_{PHZ} are the same as t_{dis} .
- F. t_{PZL} and t_{PZH} are the same as t_{en} .
- G. t_{PLH} and t_{PHL} are the same as t_{PD} .
- H. V_{CCI} is the V_{CC} associated with the input port.
- I. V_{CCO} is the V_{CC} associated with the output port.

9 Detailed Description

9.1 Overview

The UM74AVC8TX245 is an 8-bit, dual-supply non-inverting transceiver with bidirectional voltage level translation. The I/O pins labeled with A and the control pins (DIR1, DIR2 and \overline{OE}) are supported by V_{CCA} , and the I/O pins labeled with B are supported by V_{CCB} . The A port and the B port are able to accept I/O voltages ranging from 1 V to 3.6 V.

9.2 Functional Block Diagram

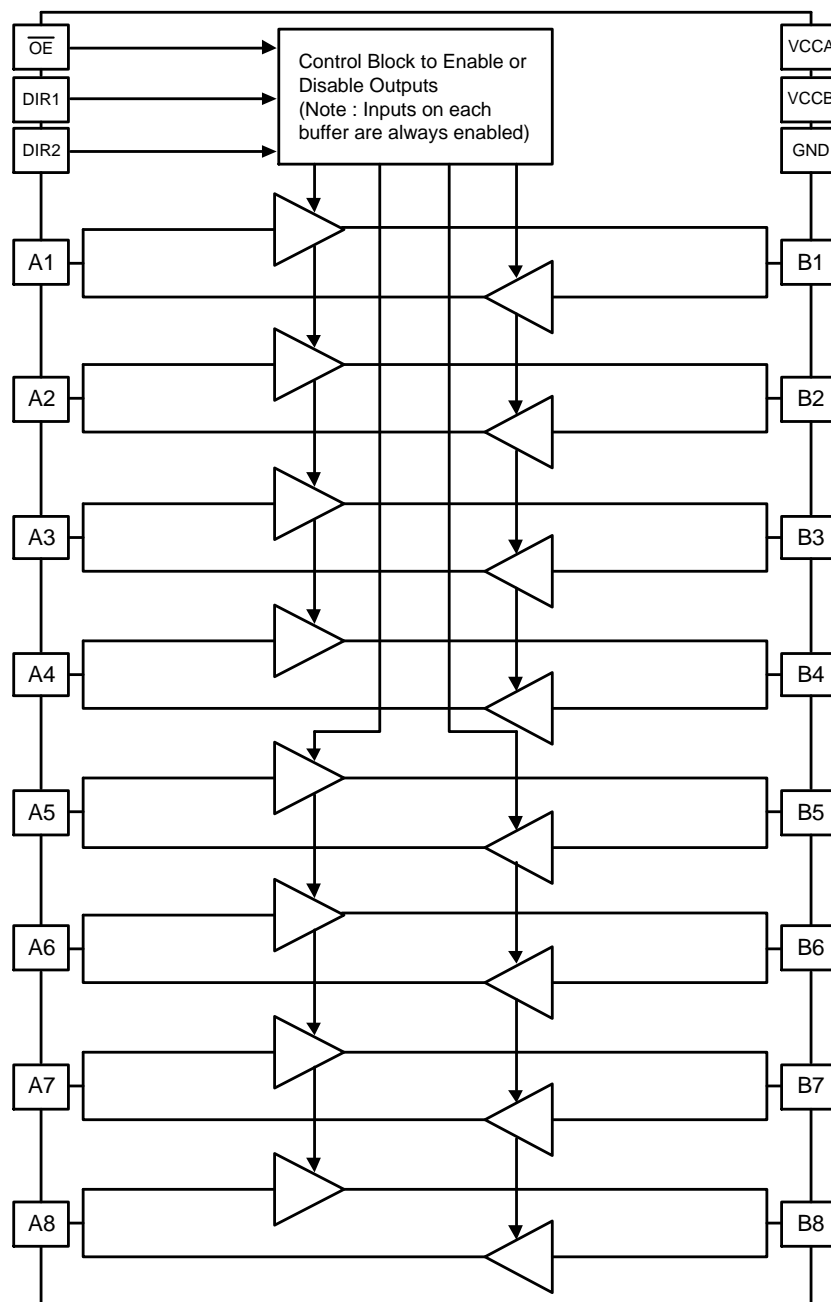

Figure 9-1. UM74AVC8TX245 Block Diagram

10 Feature Description

10.1 Fully Configurable Dual-Rail Design

The fully configurable dual-rail design allows each port to operate over the full 1 V to 3.6 V power-supply range. Both V_{CCA} and V_{CCB} can be supplied at any voltage between 1 V and 3.6 V making the device an excellent choice for translating between any of the low voltage nodes (1 V, 1.2 V, 1.8 V, 2.5 V and 3.3 V).

10.2 Multiple Direction Control Pins

Two control pins are used to configure the 8 data I/Os. I/O channels 1 through 4 are grouped together and I/O channels 5 through 8 are banked together. The benefit of this is to permit simultaneous up-translation and down-translation within one device. This eliminates the need for multiple devices, where each device can only provide up-translation or down-translation sequentially.

10.3 I_{OFF} Supports Partial-Power-Down Mode Operation

I_{OFF} prevents backflow current by disabling I/O output circuits when device is in partial power-down mode. The inputs and outputs for this device enter a high-impedance state when the device is powered down, inhibiting current backflow into the device. The maximum leakage into or out of any input or output pin on the device is specified by I_{OFF} in the Electrical Characteristics.

10.4 I/Os with Integrated Static Pull-Down Resistors

To help avoid floating inputs on the I/Os, this device has 288k Ω typical integrated weak pull-downs on all data I/Os. This feature allows all inputs to be left floating without the concern for unstable outputs or increased current consumption. This also helps to reduce external component count for applications where not all channels are used or need to be fixed low. If an external pull-up is required, it should be no larger than 30k Ω to avoid contention with the 288k Ω internal pull-down.

10.5 V_{CC} Isolation

The I/Os of both ports will enter a high-impedance state when one of the supplies are at GND, while the other supply is still connected to the device (I_{OZ} shown in Electrical Characteristics).

10.6 Device Functional Modes

All control inputs are referenced to V_{CCA} and must be driven to a valid Logic High or Logic Low (that is, not floating) to assure proper device operation and to prevent excessive power consumption. Table 10-1 summarizes the possible modes of device operation based on the configuration of the control inputs.

10.6 Device Functional Modes (continued)

Table 10-1. Function Table

Control Inputs			Signal Direction	
\overline{OE}	DIR1	DIR2	Bits 1:4	Bits 5:8
H	X	X	Disabled (Hi-Z)	
L	L	L	B to A	
L	L	H	B to A	A to B
L	H	L	A to B	
L	H	H	A to B	B to A

11 Application Information

11.1 Application Information

The UM74AVC8TX245 can be used in level-translation applications for interfacing devices or systems operating at different voltage nodes. Typical Application Circuit depicts an application in which the UM74AVC8TX245 is up-translating a 1.8V input to a 3.3V output to interface between a system controller and a peripheral device.

11.2 Typical Application

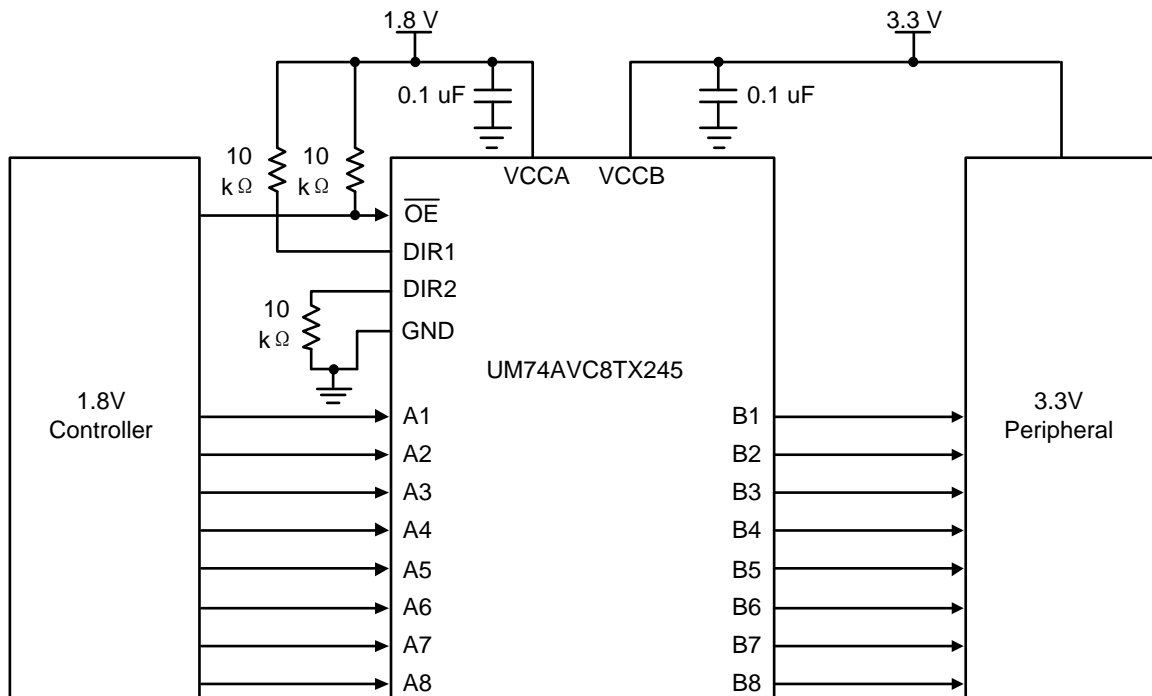
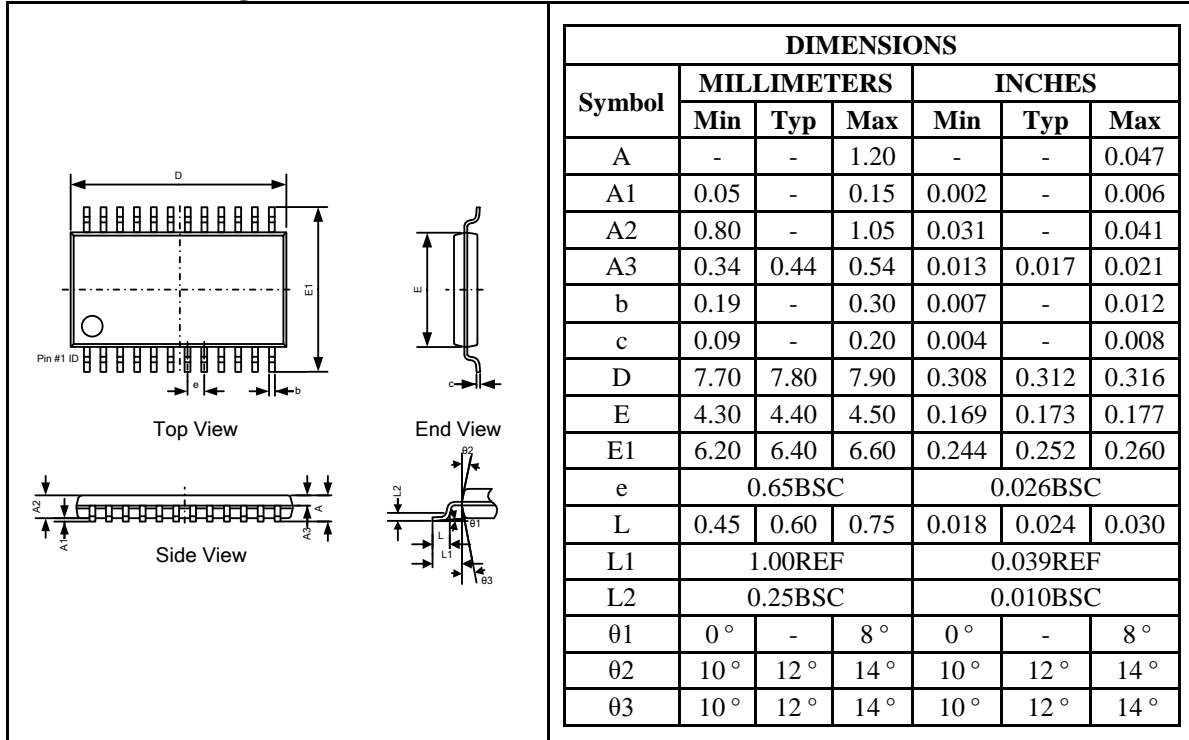

Figure 11-1. UM74AVC8TX245 Typical Application

Package Information

TSSOP24

Outline Drawing



Land Pattern

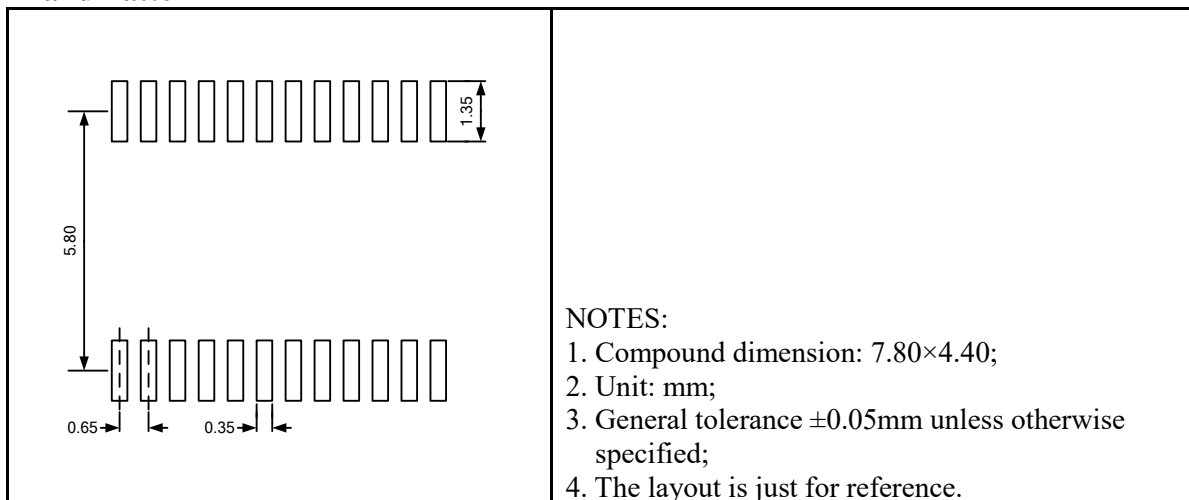

QFN24 3.5×5.5

Outline Drawing



Land Pattern

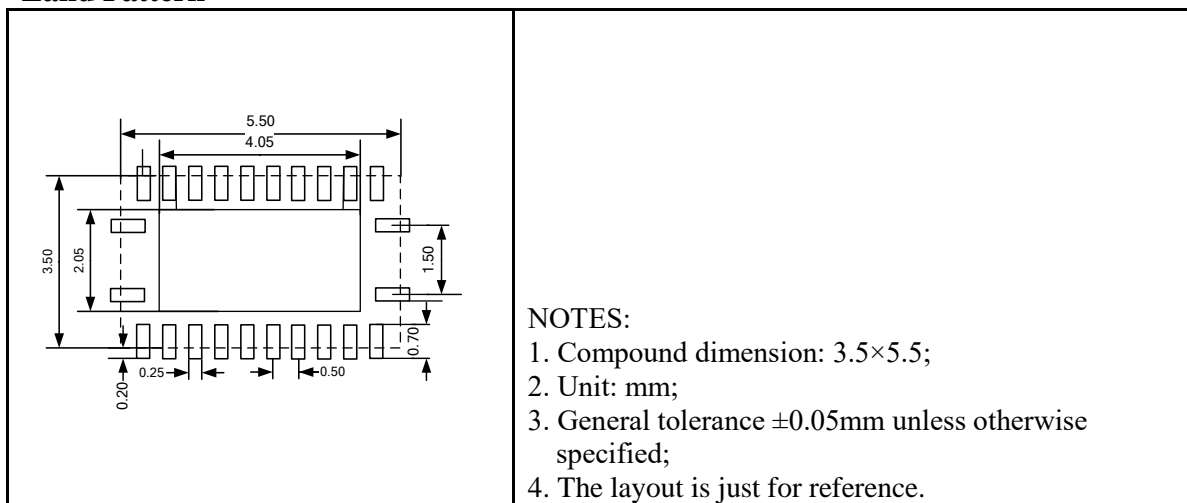

Packing Information

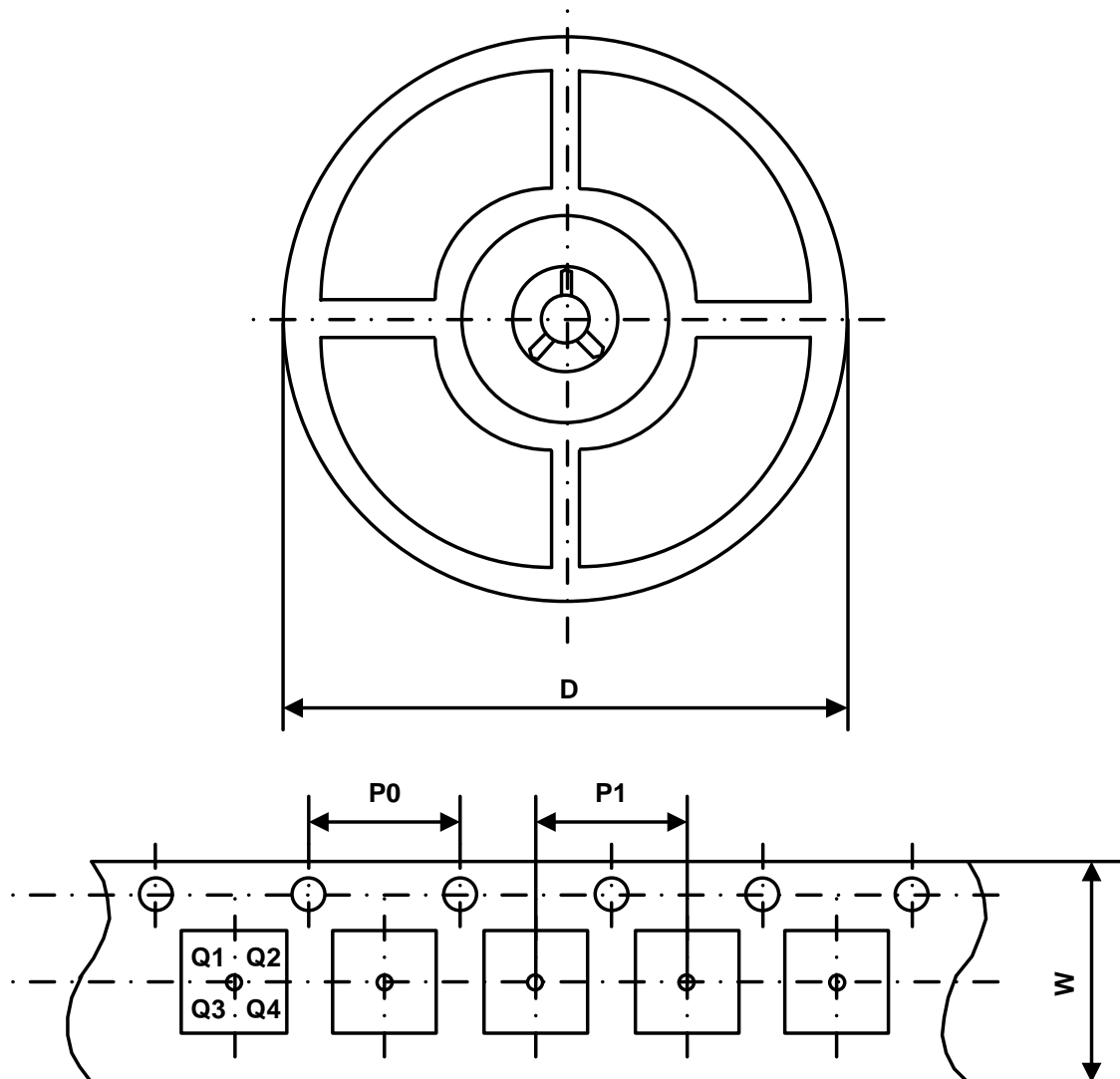

Part Number	Package Type	Carrier Width (W)	Pitch (P0)	Pitch (P1)	Reel Size (D)	PIN 1 Quadrant
UM74AVC8TX245UO	TSSOP24	16 mm	4 mm	8 mm	330 mm	Q1
UM74AVC8TX245QA	QFN24 2.0×4.0	12 mm	4 mm	4 mm	180 mm	Q1
UM74AVC8TX245QB	QFN24 3.5×5.5	12 mm	4 mm	8 mm	330 mm	Q1

GREEN COMPLIANCE

Union Semiconductor is committed to environmental excellence in all aspects of its operations including meeting or exceeding regulatory requirements with respect to the use of hazardous substances. Numerous successful programs have been implemented to reduce the use of hazardous substances and/or emissions.

All Union components are compliant with the RoHS directive, which helps to support customers in their compliance with environmental directives. For more green compliance information, please visit:

<https://www.union-ic.com/en/Quality.html>

IMPORTANT NOTICE

The information in this document has been carefully reviewed and is believed to be accurate. Nonetheless, this document is subject to change without notice. Union assumes no responsibility for any inaccuracies that may be contained in this document, and makes no commitment to update or to keep current the contained information, or to notify a person or organization of any update. Union reserves the right to make changes, at any time, in order to improve reliability, function or design and to attempt to supply the best product possible.